

HEYTEC

TOOLS

www.heytec-tools.de



Preisliste

Price list

Liste de prix

Lista de precios

2010 €



**Das Werkzeug
für Clevere!**



HEYTEC

TOOLS

Steckschlüsselgarnituren Socket Sets

- ✓ **Hochwertiger Chrom - Vanadium Stahl**
high grade chrome vanadium steel
- ✓ **DIN • EN • ISO**
- ✓ **Top Finish**
- ✓ **Stabile Kunststoffbox**
rigid 2 components plastic box

1/2" 31 pcs.



4 in 1 Knarrenschlüssel
4 in 1 gear wrenches



Gewindestange
threaded road



Einsätze mit Schonprofil und
Kreuzrändelung
Socket Sets with profile saver and cross knurling



Stabile Scharniere
solid hinge



Schnelllösemechanik
Quick release mechanism



Ergonomischer 2-K Softgriff
ergonomic soft grip handle



Schlossverriegelung möglich
locking facility



2-Komponenten-Gehäuse
rigid 2 components plastic box



Spritzwassergeschützt
splashproof



1/4" 44 pcs.



3/8" 23 pcs.



1/2" 18 pcs.



1/2" 39 pcs.



1/2"+1/4" 105 pcs.



3/4" 21 pcs.



02 – 09



11 – 23



24 – 34

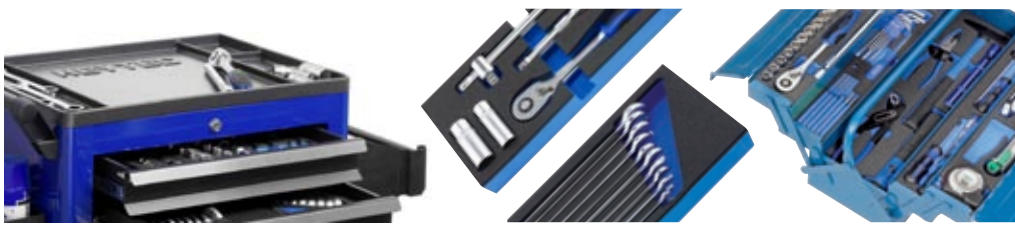

34 – 47



46 – 53



54 – 64

Indice numérico

Liste numérique

Numerical List

Nummernliste

Condiciones de venta, suministro y pago

Conditions de vente, de livraison et de paiement

Terms of Sale, Delivery and Payment

Verkaufs-, Lieferungs- und Zahlungsbedingungen

Abreviaturas, símbolos e indicaciones

Abréviations, symboles et définitions

Abbreviations, symbols and notes

Abkürzungen, Symbole und Hinweise

art.-no./página · Code-No./EAN No.

art.-no./page · Code-No./EAN No.

art.-no./page · Code-No./EAN No.

Art.-No./Seite · Code-No./EAN No.

65 – 70

Doppelmaulschlüssel

Chrom-Vanadium, verchromt,
DIN 3110 / ISO 1085

50800

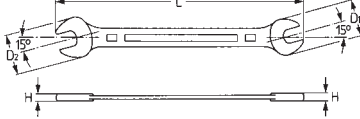
Double ended
open jaw wrenchesChrome-Vanadium, chromium plated,
DIN 3110 / ISO 1085

Clés à fourche

Chrome-Vanadium, chromés,
DIN 3110 / ISO 1085Llaves fijas de dos bocas
abiertasCromo Vanadio, cromadas,
DIN 3110 / ISO 1085

Bestell-No. Order-No.	MM	CL mm	H mm	D1 mm	D2 mm	g		€
50800060780	6 x 7	122	3,6	15,7	17,7	18	10	1,30
50800080980	8 x 9	140	3,9	20,8	22,9	32	10	1,40
50800081080	8 x 10	140	3,9	20,8	22,9	32	10	1,50
50800101180	10 x 11	156	4,8	23,9	26,9	54	10	1,50
50800101380	10 x 13	172	5,3	28,0	31,0	67	10	1,65
50800111380	11 x 13	172	5,5	28,0	29,8	75	10	1,70
50800121380	12 x 13	172	5,3	28,0	31,0	61	10	1,70
50800131580	13 x 15	190	5,7	32,5	34,9	89	10	2,00
50800131780	13 x 17	204	5,9	32,1	38,2	110	10	2,25
50800141580	14 x 15	190	5,7	32,5	34,9	90	10	2,00
50800161780	16 x 17	204	5,9	36,1	39,2	105	10	2,25
50800161880	16 x 18	204	5,9	36,1	39,2	115	10	2,50
50800171980	17 x 19	223	6,5	40,2	42,3	155	10	2,70
50800181980	18 x 19	223	6,5	40,2	42,3	150	10	2,70
50800192280	19 x 22	236	6,8	44,9	48,4	190	10	3,55
50800202280	20 x 22	236	6,8	44,9	48,4	185	10	3,55
50800212380	21 x 23	250	7,3	47,4	51,5	265	5	3,95
50800242780	24 x 27	265	7,8	52,5	58,6	310	5	4,55
50800252880	25 x 28	280	8,1	55,2	61,3	350	5	5,60
50800273080	27 x 30	280	8,1	58,6	64,4	355	5	6,80
50800303280	30 x 32	302	8,6	64,8	70,3	480	5	7,50

Doppelmaulschlüssel-Sätze

Sets of double ended open
jaw wrenches

Jeux de clés à fourche

Juegos de llaves fijas de dos
bocas abiertasK 50800 · HP 50800
B 50800 · R 50800

K 50800



B 50800



HP 50800



R 50890

Bestell-No. Order-No.	Art.No.	MM	g		€
50800944080	K 50800-8-M	6x7 · 8x9 · 10x11 · 12x13 · 14x15 16x17 · 18x19 · 20x22	695	1	16,35
50800947080	K 50800-12-M	6x7 · 8x9 · 10x11 · 12x13 · 14x15 16x17 · 18x19 · 20x22 · 21x23 24x27 · 25x28 · 30x32	2100	1	38,05
50800844080	B 50800-8-M	6x7 · 8x9 · 10x11 · 12x13 · 14x15 16x17 · 18x19 · 20x22	710	1	19,80
50800644080	HP 50800-8-M	6x7 · 8x9 · 10x11 · 12x13 · 14x15 16x17 · 18x19 · 20x22	790	1	17,90
50800747080	R 50800-12-M	6x7 · 8x9 · 10x11 · 12x13 · 14x15 16x17 · 18x19 · 20x22 · 21x23 24x27 · 25x28 · 30x32	2101	1	42,75
50890300200	R 50890-12-M	6x7 · 8x9 · 10x11 · 12x13 · 14x15 16x17 · 18x19 · 20x22 · 21x23 24x27	1990	1	48,50
		240 mm			
		255 mm / 10"			

- Cuerpo de acero al cromo vanadio, forjado, templado, cabeza pulida, recubrimiento de níquel y cromo resistente a la corrosión
- Bocas fresadas y templadas por inducción
- Accionamiento preciso del sinfín templado
- Escala métrica y en pulgadas, impresa por laser
- Mango recubierto de plástico antideslizante y agradable al tacto
- Modelo americano con ángulo de boca de 22°, giro a la derecha

- Corps trempé et forgé dans un acier au Chrome Vanadium de haute qualité, avec tête meulée et galvanisé d'une couche de Chrome-Nickel contre la corrosion.
- Mâchoire fraisée et trempe spéciale
- Guidage précis de la molette à vis, trempée
- Echelles métrique et en pouces imprimées au laser
- Poignée en matière synthétique glisse et respectant la peau
- Modèle américain avec mâchoire à 22°, tournant à droite

- Chrome-Vanadium steel body, drop forged and hardened, polished head, nickel and chromium plated for protection against corrosion
- specially hardened and milled jaws
- precise running of hardened worm-wheel
- laser-marked scale in metric and inch graduation
- comfortable non-slip plastic handle
- American pattern with 22° angled head and right hand movement

- geschmiedeter, gehärteter Schlüsselkörper aus hochwertigem Chrom-Vanadium-Stahl mit geschliffenem Schlüsselkopf, mit Nickel-Chromschicht galvanisiert gegen Korrosion
- spezialgehärtete, gefräste Greifbacken
- präzise Führung des gehärteten Schneckenrads
- gelaserte metrische und Zoll-Skala
- hautsympathischer, rutschsicherer Kunststoffgriff
- amerikanisches Modell mit 22° Maulstellung, rechtsgängig

Llaves ajustables

Clés à molette

Adjustable wrenches

Einmaulschlüssel verstellbar

Cromo Vanadio, cromadas, con mango de plástico y escala

Chrome-Vanadium, chromés, avec poignée souple et et graduation

Chrome-Vanadium, chromium plated, with soft grip plastic handle and scale

Chrom-Vanadium, verchromt, mit Kunststoff-Handschutz und Skala

50839



Bestell-No. Order-No.	Art.No.	CL	mm	"	MM/AF	g		€
50839000680	50839	160	6	0 - 20	0 - 1/4"	160	5	6,65
50839000880	50839	205	8	0 - 25	0 - 1"	310	5	9,10
50839001080	50839	255	10	0 - 30	0 - 1 1/4"	540	5	12,30
50839001280	50839	305	12	0 - 35	0 - 1 1/2"	800	5	16,25

Juegos de llaves ajustables

Jeux de Clés à molette

Sets of Adjustable Wrenches

Sätze mit verstellbaren Einmaulschlüsseln

K 50839-3



Bestell-No. Order-No.	Art.No.	MM/AF	g		€
50839000100	K 50839-3	0 - 30 0 - 1 1/4"	1010	1	27,95

enthaltend je 1 St.:
containing each 1 pce.:
composition chaque 1 pce.:
contiene una pza. de cada:
50839-6 · 50839-8 · 50839-10

Ringmaulschlüssel

Combination wrenches

Clés mixtes

Llaves combinadas

Chrom-Vanadium, verchromt,
Schon-Profil
DIN 3113 A / ISO 7738

Chrome-Vanadium, chromium plated,
profile saver
DIN 3113 A / ISO 7738

Chrome-Vanadium, chromés,
profil de protection SP
DIN 3113 A / ISO 7738

Cromo Vanadio, cromadas,
perfil especial SP
DIN 3113 A / ISO 7738

50810

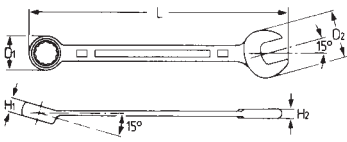

Bestell-No. Order-No.	Ø MM	CL mm	H1 mm	H2 mm	D1 mm	D2 mm	g	mm	€
50810006080	6	100	5,0	3,9	9,8	15,7	12	10	1,35
50810007080	7	110	5,5	4,2	11,2	17,0	18	10	1,35
50810008080	8	120	5,9	4,4	12,7	19,0	23	10	1,40
50810009080	9	130	6,4	4,7	14,1	20,9	33	10	1,45
50810010080	10	140	6,9	5,0	15,5	22,8	40	10	1,50
50810011080	11	150	7,4	5,2	16,9	25,4	48	10	1,60
50810012080	12	160	7,9	5,5	18,3	26,7	58	10	1,70
50810013080	13	170	8,4	5,8	19,7	29,3	63	10	1,80
50810014080	14	180	8,9	6,1	21,1	31,2	88	10	1,95
50810015080	15	190	9,3	6,3	22,6	33,0	97	10	2,00
50810016080	16	200	9,8	6,6	24,0	34,5	105	10	2,05
50810017080	17	210	10,3	6,9	25,4	37,3	130	10	2,15
50810018080	18	220	10,8	7,1	26,8	38,4	145	10	2,70
50810019080	19	230	11,1	7,3	28,2	40,4	145	10	3,10
50810020080	20	240	11,4	7,5	29,6	42,3	165	10	3,20
50810021080	21	250	11,7	7,7	31,0	44,2	190	10	3,60
50810022080	22	260	12,0	7,9	32,3	46,6	225	10	4,40
50810024080	24	280	12,7	8,3	35,1	50,1	265	5	5,35
50810027080	27	310	13,6	8,9	39,2	55,9	330	5	6,75
50810030080	30	340	14,6	9,5	43,4	62,6	430	5	7,95
50810032080	32	360	15,2	9,9	46,2	66,9	515	5	8,15

Das HEYTEC-Schonprofil

The HEYTEC-profile saver

Le profil de protection
HEYTEC

Perfil especial SP HEYTEC

Schont Schrauben und Muttern. Setzt an
den Flächen und nicht an den Kanten an.
Eine positive Auswirkung ist die erheblich
längere Lebensdauer.

Protects screws and nuts whilst
forces are applied on the flanks
and not on edges, providing a
much extended lifetime.

Protège boulons et écrous, s'appuie
sur les flancs et pas sur les arêtes,
Un effet positif sur la durée de vie
de la vis et de l'outil.

Reduce el desgaste en tornillos y
tuercas, porque presiona sobre
los planos y no sobre los cantos,
dando como resultado una
durabilidad netamente superior.

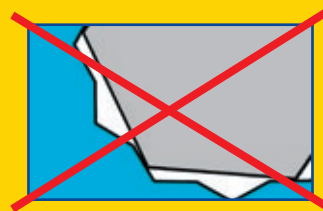

10

34

Juegos de llaves combinadas

Cromo Vanadio, cromadas, perfil especial SP
DIN 3113 A / ISO 7738

Jeux de clés mixtes

Chrome-Vanadium, chromés, profil de protection SP
DIN 3113 A / ISO 7738

Sets of combination wrenches

Chrome-Vanadium, chromium plated, profile saver
DIN 3113 A / ISO 7738

Ringmaulschlüssel-Sätze

Chrom-Vanadium, verchromt, Schon-Profil
DIN 3113 A / ISO 7738



**B 50810 · HP 50810
K 50810 · R 50810**

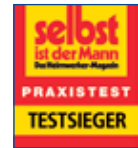

Im Test 8-tlg. Sätze
"Sehr gut" optisch und
technisch hervorragend.
(Test 8.2005)



B 50810



HP 50810-12



K 50810



R 50810



R 50810-21

Bestell-No. Order-No.	Art.No.				€
50810924280	K 50810-8-M	8-9-10-11-13-14-17-19	570	1	14,80
50810927180	K 50810-12-M-1	8-9-10-11-12-13-14-15-16-17-18-19	1055	1	23,30
50810927280	K 50810-12-M-2	6-7-8-9-10-11-12-13-14-17-19-22	1135	1	23,55
50810929080	K 50810-17-M	6-7-8-9-10-11-12-13-14-15-16-17 18-19-20-21-22	1575	1	37,10
50810929480	K 50810-21-M	6-7-8-9-10-11-12-13-14-15-16-17 18-19-20-21-22-24-27-30-32	4080	1	65,20
50810824280	B 50810-8-M	8-9-10-11-13-14-17-19	590	1	17,95
50810827180	B 50810-12-M	8-9-10-11-12-13-14-15-16-17-18-19	980	1	26,95
50810724280	R 50810-8-M	8-10-12-13-14-15-17-19	675	1	21,25
50810727180	R 50810-12-M-1	8-9-10-11-12-13-14-15-16-17-18-19	1055	1	32,00
50810727280	R 50810-12-M-2	6-7-8-9-10-11-12-13-14-17-19-22	1055	1	32,25
50810729480	R 50810-21-M	6-7-8-9-10-11-12-13-14-15-16-17 18-19-20-21-22-24-27-30-32	3350	1	74,90
50810627380	HP 50810-12-M	8-10-11-12-13-14-15-16-17-18-19-22	1270	1	29,50



Doppelringschlüssel
tief gekröpftChrom-Vanadium, verchromt,
Schon-Profil
DIN 838 / ISO 1085

50805

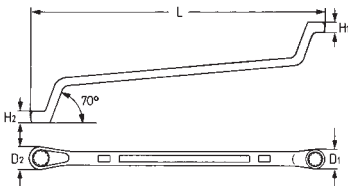
Double ended ring wrenches
deep offsetChrome-Vanadium, chromium plated,
profile saver
DIN 838 / ISO 1085Clés polygonales
contre-coudées profondémentChrome-Vanadium, chromés,
profil de protection SP
DIN 838 / ISO 1085Llaves de estrella acodadas,
de dos bocasCromo Vanadio, cromadas,
acodado profundo,
perfil especial SP
DIN 838 / ISO 1085

Bestell-No. Order-No.	MM	mm	H1 mm	H2 mm	D1 mm	D2 mm	g		€
50805060780	6 x 7	165	5,9	6,5	11,1	12,5	40	10	1,80
50805080980	8 x 9	180	6,9	7,4	14,3	15,5	58	10	1,90
50805101180	10 x 11	200	7,8	8,3	17,2	18,4	72	10	2,00
50805121380	12 x 13	220	8,8	9,3	20,6	21,3	108	10	2,15
50805141580	14 x 15	245	9,7	10,2	23,3	24,2	140	10	2,35
50805161780	16 x 17	255	10,6	10,9	26,4	27,2	175	5	2,70
50805171980	17 x 19	285	12,0	12,0	26,8	28,5	285	5	3,95
50805181980	18 x 19	275	11,3	11,6	29,1	30,1	235	5	3,35
50805202280	20 x 22	300	12,0	12,7	31,1	34,0	285	5	4,10
50805212380	21 x 23	315	12,4	13,1	33,0	36,0	305	5	4,60
50805242780	24 x 27	330	13,4	14,5	38,5	41,9	360	5	5,30
50805252880	25 x 28	350	13,8	14,9	40,4	43,9	450	5	5,90
50805303280	30 x 32	365	15,9	16,5	46,8	49,3	550	5	7,10

Doppelringschlüssel
tief gekröpftChrom-Vanadium, verchromt,
Schon-Profil
DIN 838 / ISO 1085K 50805 · R 50805
HP 50805

R 50805

Double ended ring wrenches
deep offsetChrome-Vanadium, chromium plated,
profile saver
DIN 838 / ISO 1085Clés polygonales
contre-coudées profondémentChrome-Vanadium, chromés,
profil de protection SP
DIN 838 / ISO 1085Llaves de estrella acodadas,
de dos bocasCromo Vanadio, cromadas,
acodado profundo,
perfil especial SP
DIN 838 / ISO 1085

K 50805



HP 50805



Bestell-No. Order-No.	Art.No.	MM	g		€
50805944080	K-50805-8-M	6x7 · 8x9 · 10x11 · 12x13 · 14x15 · 16x17 18x19 · 20x22	1120	1	20,20
50805947080	K-50805-12-M	6x7 · 8x9 · 10x11 · 12x13 · 14x15 · 16x17 18x19 · 20x22 · 21x23 · 24x27 · 25x28 · 30x32	2950	1	43,10
50805747080	R-50805-12-M	6x7 · 8x9 · 10x11 · 12x13 · 14x15 · 16x17 18x19 · 20x22 · 21x23 · 24x27 · 25x28 · 30x32	3100	1	52,20
50805644080	HP-50805-8-M	6x7 · 8x9 · 10x11 · 12x13 · 14x15 · 16x17 18x19 · 20x22	1320	1	24,90

Llaves combinadas boca estrella con carraca

Clés mixtes à cliquet

Combination ratchet wrenches

Knarren-Ringmaulschlüssel

Cromo Vanadio, cromadas, par de apriete: boca estrella según DIN 899 serie A / ISO 1711-1 boca abierta según DIN 899 serie C / ISO 1711

Chrome Vanadium, chromés, 72 dents, couple côté polygonal suivant DIN 899 rang A / ISO 1711-1 fourche suivant DIN 899 rang C / ISO 1711

Chrome Vanadium, chromium plated, 72 teeth, torque on ring to DIN 899 row A / ISO 1711-1 on open end to DIN 899 row C / ISO 1711

Chrom-Vanadium, verchromt, 72 Zähne, Drehmoment Ring nach DIN 899 Reihe A / ISO 1711-1 Maul nach DIN 899 Reihe C / ISO 1711

50720

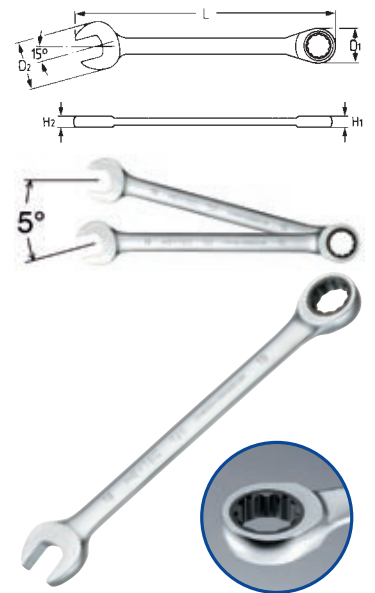

Bestell-No. Order-No.	MM	mm	H1 mm	H2 mm	D1 mm	D2 mm	g		€
50720008080	8	140,0	6,6	4,6	17,0	16,8	32	10	9,00
50720009080	9	150,0	7,0	5,0	19,5	18,5	40	10	9,20
50720010080	10	160,0	7,5	5,3	20,5	20,8	59	10	9,40
50720011080	11	165,0	8,0	6,0	22,2	23,0	70	10	9,65
50720012080	12	172,0	8,3	6,3	23,0	25,3	77	10	10,30
50720013080	13	178,0	8,7	6,6	25,3	27,2	85	10	11,00
50720014080	14	190,0	9,0	6,8	28,2	29,2	105	10	11,40
50720015080	15	200,0	9,5	7,0	29,2	31,5	125	10	11,95
50720016080	16	207,0	10,0	7,5	30,0	32,8	225	10	12,60
50720017080	17	225,0	10,3	7,7	31,7	35,0	160	10	13,25
50720018080	18	240,0	11,5	8,3	32,2	37,5	200	10	14,15
50720019080	19	248,0	10,3	8,7	34,3	39,5	210	10	14,45

Juegos de llaves combinadas boca estrella con carraca

Jeux de clés mixtes à cliquet

Sets of combined ratchet wrenches

Knarren-Ringmaulschlüssel-Sätze

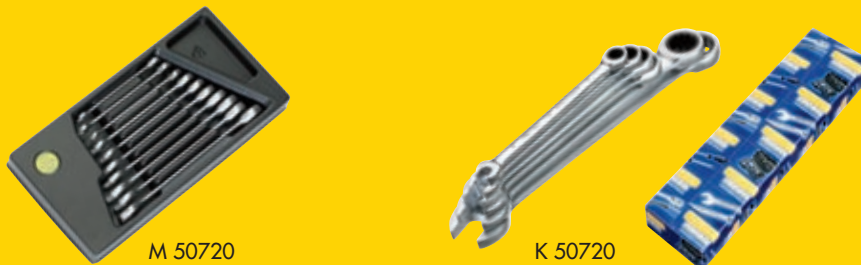

K 50720 · R 50720
M 50720

Bestell-No. Order-No.	Art.No.	MM	g		€
50720600080	K 50720-6-M	8-10-12-13-17-19	623	1	67,50
50720600180	R 50720-6-M	8-10-12-13-17-19	755	1	77,05
50720600380	R 50720-8-M	8-10-12-13-14-15-17-19	1005	1	99,00
50720600280	M 50720-10-M	8-10-12-13-14-15-16-17-18-19	1400	1	133,75



R 50720

Adaptador para llaves combinadas boca estrella con carraca

Adaptateur pour clés mixtes à cliquet

Adapter for combination ratchet wrenches

Adapter für Knarren-Ringmaulschlüssel

50825-12 · 50840-12
50850-12

Bestell-No. Order-No.	Art.No.	■	für · for · pour · para HEYTEC No.	MM	g		€
50825121083	50825-1210	1/4"	50720	10	6	10	7,45
50840121383	50840-1213	3/8"	+	13	18	10	8,10
50850121983	50850-1219	1/2"	50725	19	50	10	8,55



Knarren-Ringmaulschlüssel
umschaltbar

Chrom-Vanadium, verchromt,
72 Zähne, Drehmoment Ring
nach DIN 899 Reihe A / ISO 1711-1
Maul nach
DIN 899 Reihe C / ISO 1711

50725

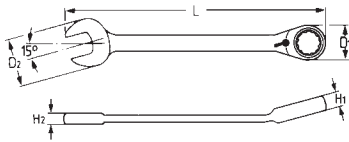
Combination ratchet wrenches,
reversible

Chrome-Vanadium, chromium plated,
72 teeth, torque on ring
to DIN 899 row A / ISO 1711-1
on open end
to DIN 899 row C / ISO 1711

Clés mixtes à cliquet
réversible

Chrome-Vanadium, chromées,
72 dents, couple côté polygonal
suivant DIN 899 rang A / ISO
1711-1 fourche suivant DIN 899 rang
C / ISO 1711

Llaves combinadas boca
estrella con carraca reversible

Cromo Vanadio, cromadas,
par de apriete: boca estrella según
DIN 899 serie A / ISO 1711-1
boca abierta según
DIN 899 serie C / ISO 1711

Bestell-No. Order-No.	MM	mm	H1 mm	H2 mm	D1 mm	D2 mm	g		€
50725008080	8	140,0	8,2	5,3	17,0	17,0	37	10	12,25
50725009080	9	150,0	8,2	5,5	19,0	18,8	47	10	12,25
50725010080	10	160,0	8,4	6,0	20,5	21,7	62	10	12,90
50725011080	11	165,0	9,4	6,4	21,5	23,0	71	10	12,90
50725012080	12	170,0	9,4	6,5	22,5	25,2	84	10	13,25
50725013080	13	178,0	9,4	7,3	24,0	26,5	95	10	13,25
50725014080	14	190,0	9,4	7,5	26,5	29,6	112	10	15,40
50725015080	15	200,0	9,4	7,8	28,0	31,3	142	10	15,40
50725016080	16	210,0	11,1	8,1	29,0	33,4	155	10	18,30
50725017080	17	225,0	11,1	8,4	30,5	36,3	175	10	18,30
50725018080	18	237,0	12,4	9,1	31,5	38,0	210	10	19,65
50725019080	19	248,0	12,4	9,3	33,0	39,0	235	10	19,65
50725022080	22	290,0	13,0	9,3	39,0	46,0	380	10	29,05
50725024080	24	335,0	14,5	10,4	45,5	52,3	530	5	34,35

Knarren-Ringmaulschlüssel-
Sätze, umschaltbarSets of combined ratchet
wrenches, reversibleJeux de clés mixtes à cliquet
réversibleJuegos de llaves combinadas
boca estrella con carraca reversibleK 50725 · R 50725
M 50725

K 50725



R 50725-8



M 50725



Adapter siehe Seite 7
Adapter see page 7
Adaptateur voir page 7
Adaptador véase página 7

Bestell-No. Order-No.	Art.No.	MM	g		€
50725600080	K 50725-6-M	8-10-12-13-17-19	690	1	89,60
50725600180	R 50725-6-M	8-10-12-13-17-19	825	1	98,90
50725600380	R 50725-8-M	8-10-12-13-14-15-17-19	974	1	129,60
50725600280	M 50725-10-M	8-10-11-12-13-14-16-17-18-19	1550	1	171,55

Llave boca estrella
con carraca „4 en 1“

Cromo vanadio, cromada,
con carraca reversible, 72 dientes

4 en 1 clé polygonale
à cliquet

Chrome-Vanadium, chromées,
avec cliquet réversible, 72 dents

4 in 1 ratcheting wrench

Chrome-Vanadium, chromium plated,
with reversible ratchet, 72 teeth

4 in 1 Knarrenringschlüssel

Chrom-Vanadium, verchromt,
mit Hebelumschaltknarre · 72 Zähne



50730



Bestell-No. Order-No.	Art.No.	CL Ø mm	MM	g	mm	€
50730081383	50730	165	8 x 10 x 12 x 13	105	5	19,00
50730091583	50730	180	9 x 11 x 14 x 15	150	5	22,00
50730161983	50730	225	16 x 17 x 18 x 19	255	5	25,00
50730202483	50730	255	20 x 21 x 22 x 24	480	5	44,00

Cinturón portaherramientas
de tela, con cierre de velcro

3 pzs.

Etui de ceinture résistant avec
fermeture velcro

3 pcs.

Solid textile belt bag
with velcro sealing

3 pcs.

Stabile Textil-Gürteltasche
mit Klettverschluss

3-tlg.



R 50730-3



Bestell-No. Order-No.	Art.No.	MM	g	mm	€
50730600183	R 50730-3	8 x 10 x 12 x 13 9 x 11 x 14 x 15 16 x 17 x 18 x 19	495	1	79,00

Herramientas para el
montaje de andamios

Cromo Vanadio, fosfatado

La Herramienta ideal para profesionales de la construcción. Con nuestra llave de carraca para el montaje de andamios dispone Vd. de una herramienta robusta que incorpora una carraca reversible con agujero para el paso de la varilla roscada. El mango termina en con para un ajuste rápido de los elementos del andamio.

Outils pour monteurs
d'échafaudages

Chrome-Vanadium, phosphaté

L'outil idéal pour les pros du Bâtiment. Avec notre cliquet pour le montage d'échafaudages, vous disposez d'un modèle extrêmement robuste avec cliquet réversible et un passage pour les tiges filetées. L'extrémité de la poignée est conçue en forme de mandrin et permet ainsi un ajustement rapide des éléments à assembler

Construction Tools

Chrome-Vanadium, phosphated

This scaffolding ratchet-tool is an extremely robust product with reversible ratchet and pass-through feature for threaded bolts. With „rat-tail“ handle for aligning construction parts.

Gerüstbauknarre

Chrom-Vanadium, phosphatiert

Diese Gerüstbauknarre ist ein extrem stabiles Modell, mit umschaltbarer Knarre und einem Durchlass für den Gewindebolzen. Das Ende des Handgriffs ist als Dorn ausgeführt und ermöglicht somit ein schnelles justieren der Bauteile.

50740



Bestell-No. Order-No.	Art.No.	CL Ø mm	MM	g	mm	€
50740192236	50740	315	19 x 22	150	2	27,50

HEYTEC

TOOLS

macht mobil!

brings mobility

Werkstattswagen und Module
Workshop trolley and modules



HEYlights

stabile Metallkonstruktion
rigid metal construction

verwindungssteif und hochbelastbar
resisting torsional forces for high loads

5 Schubfächer mit Kugelführungen
5 drawers with ball bearings

großes Staufach für Geräte und Maschinen
large storage room for machines and equipment

Zentralverriegelung mit Zylinderschloss
central locking with cylinder lock

stabiler Schiebegriff
strong handle

Lenkrolle, feststellbar
steering roller with brake

Entriegelung mit Einhandbedienung
single-handed unlocking

Kugelgelagerter Vollauszug
fully extendable drawers with ball bearings

Accesorios

Accessoires

Accessories

Antriebs- und Verbindungsteile

1/4"

Cromo Vanadio, cromadas

Chrome-Vanadium, chromées

Chrome-Vanadium, chromium plated

Chrom-Vanadium, verchromt

50825-00-15 – 50825-08

1/4"

1/4"



50825-00-15



50825-10-15



50825-20-15



50825-04



50825-03



50825-05



50800-3306



50825-06



50825-05-5



50825-08

Carraca reversible

con expulsor para separación instantánea de vasos y accesorios

50825-00-15

Con mango ergonómico de dos componentes
DIN 3122 D · ISO 3315

Cliquets réversibles

tige d'éjection pour libérer rapidement l'outil du cliquet

50825-00-15

Avec poignée ergonomique à 2 composants
DIN 3122 D · ISO 3315

Lever type reversible ratchet

with quick release ejector button
with ergonomic 2 components handle
DIN 3122 D · ISO 3315

50825-00-15

Hebelumschaltknarren

mit Auswerferstift zum Schnellösen der Steckverbindung

50825-00-15

mit ergonomischem 2-K Griff
DIN 3122 D · ISO 3315

50825-10-15

Mango acodado, plastificado
DIN 3122 D · ISO 3315

50825-10-15

Poignée en acier déporté à enrobage plastique
DIN 3122 D · ISO 3315

50825-10-15

Offset handle, plastic coated
DIN 3122 D · ISO 3315

50825-10-15

Gebogener Stahlkern, kunststoffummantelt
DIN 3122 D · ISO 3315

50825-20-15

Mango acodado

50825-20-15

en acier

50825-20-15

All steel reversible ratchet, with offset handle

50825-20-15

Gebogene Ganzstahlknarre

50825-03 · Mango corredizo
DIN 3123 B · ISO 3316

50825-03 · Poignée coulissante
DIN 3123 B · ISO 3316

50825-03 · Sliding T-handles
DIN 3123 B · ISO 3316

50825-03 · Griffe mit Gleitstück
DIN 3123 B · ISO 3316

50825-04/05/05-5 · Alargaderas
DIN 3123 B · ISO 3316

50825-04/05/05-5 · Rallonges
DIN 3123 B · ISO 3316

50825-04/05/05-5 · Extension bars
DIN 3123 B · ISO 3316

50825-04/05/05-5 · Verlängerungen
DIN 3123 B · ISO 3316

50825-06 · Articulaciones universales
DIN 3123 C · ISO 3316

50825-06 · Cardan universel
DIN 3123 C · ISO 3316

50825-06 · Universal joints
DIN 3123 C · ISO 3316

50825-06 · Kardangelenke
DIN 3123 C · ISO 3316

50825-08 · Mango recto
DIN 3122 E · ISO 3315

50825-08 · Rallonges emmanchée
DIN 3122 E · ISO 3315

50825-08 · Spinner handles
DIN 3122 E · ISO 3315

50825-08 · Steckgriffe
DIN 3122 E · ISO 3315

50800-3306

Adaptador para puntas de 1/4" hexágono interior, con pinza de sujeción

50800-3306

Adaptateur pour embouts de 1/4" à pans femelle, avec clavette de blocage

50800-3306

Adapter for 1/4" bits
Internal hexagon with holding clip

50800-3306

Adapter für 1/4" Bits
Innensechskant, mit Halteklammer

Bestell-No. Order-No.	Art.No.		 mm			€
50825015083	50825-00-15	1/4"	150	135	5	13,50
50825101500	50825-10-15	1/4"	148	97	5	21,45
50825201583	50825-20-15	1/4"	95	57	5	19,50
50825030083	50825-03	1/4"	115	42	10	2,30
50825040083	50825-04	1/4"	50	35	10	1,15
50825050083	50825-05	1/4"	100	44	10	1,50
50825055083	50825-05-5	1/4"	102	43	5	2,80
50825060083	50825-06	1/4"	37	26	10	3,75
50825080083	50825-08	1/4"	150	98	10	2,50
50800330683	50800-3306	1/4"	25	20	10	0,70

Verbindungselemente für Bohrmaschinen und Akkuschrauber

Adapter set for drilling and screwing machines

Adaptateur pour perceuse et visseuse à batterie

Adaptadores para taladros y destornilladores eléctricos

Bit-Box-Satz 32-tlg.,

Chrom-Vanadium, gesandstrahlt, mit magnetischem Schnellwechseladapter und Adapter für 1/4" Vierkant-Halter, mit Gürtelhalter und Bohrung für Wandaufhängung

50833-2**Bit-box-set 32 pcs.,**

Chrome-Vanadium, sand blasted, with magnetic quick changing adapter for 1/4" tool-holder with belt clip and borehole for wallmounting

Jeu d'embouts de 32 pcs.,

Chrome-Vanadium, sablé, avec adaptateur magnétique à éjection rapide, et adaptateur pour porteoutil 1/4" carré avec adaptateur de ceinture et trou de suspension murale

Juego de 32 puntas en caja,

Cromo Vanadio, granallado, con adaptador imanitado de cambio rápido, sujeción de cinturón y agujero para colgar de la pared

**NEW**

in/en Box/caja
HEYTEC No. 50800-3306
Seite/page 11

- R1-R2
- 3,5 · 4,5 · 5,5 · 6,5 · 8
- ✚ PH1 · PH2 (2x) · PH3
- ✚ PZ1 · PZ2 (2x) · PZ3
- ⬡ 2 · 3 · 4 · 5 · 6 · 7 · 8
- ⚙ TT9 · 10 · 15 · 20 · 25 · 27 · 30 · 40

Bestell-No. Order-No.	Art.No.	Maße · Dimensions · Medidas			€
50833200000	50833-2	105 x 65 x 40 mm	250	5	14,10

Adapter-Satz 3-tlg.

Adapter-set 3 pcs.

Jeu de adapteurs de 3 pcs.

Juego de 3 adaptadores

Chrom-Vanadium-Stahl, gesandstrahlt, je 1 Adapter 1/4" - 3/8" - 1/2" Vierkant mit Kugel, Länge 75mm für Maschinenbetrieb, 1/4" Sechskant Antrieb

Chrome-Vanadium steel, sand blasted, 1 adapter each for 1/4", 3/8", 1/2" square drive with ball, 75 mm long for usage in machines 1/4" hexagon drive

Acier au Chrome Vanadium, sablé, 1 adaptateur de chaque à carré de 1/4"-3/8"-1/2" avec bille, longueur 75 mm pour utilisation sur machine, entraînement hexagonal 1/4"

Acero al cromo vanadio, granallado, 1 adaptador de cada uno de los cuadradillos con bola de 1/4", 3/8" y 1/2", largo 75 mm para uso en máquina, punta exagonal de 1/4"

9083312-3

Bestell-No. Order-No.	Art.No.		CL mm			€
90833120305	9083312-3	1/4"	65	20	10	9,35
		3/8"	65	26		
		1/2"	65	32		

LLAVES DE VASO,
BOCA HEXAGONAL

DOUILLES, 6 PANS

SOCKETS, HEXAGON

STECKSCHLÜSSELEINSÄTZE, SECHSKANT
DIN 3124 / ISO 2725

Cromo Vanadio, cromadas

Chrome-Vanadium, chromées

Chrome-Vanadium, chromium plated

Chrom-Vanadium, verchromt

Bestell-No. Order-No.	ØMM	CLØ mm	T mm	D1 mm	D2 mm	g	mm	€
50825600483	4	25,0	9,0	7,0	12,0	9	10	0,70
50825604583	4,5	25,0	9,0	7,0	12,0	10	10	0,70
50825600583	5	25,0	9,0	8,0	12,0	10	10	0,70
50825605583	5,5	25,0	9,0	9,0	12,0	9	10	0,70
50825600683	6	25,0	9,0	9,0	12,0	10	10	0,70
50825600783	7	25,0	9,0	10,0	12,0	11	10	0,70
50825600883	8	25,0	9,0	12,0	12,0	12	10	0,70
50825600983	9	25,0	11,0	13,0	13,0	14	10	0,70
50825601083	10	25,0	11,0	14,0	14,0	15	10	0,70
50825601183	11	25,0	12,0	16,0	16,0	21	10	0,85
50825601283	12	25,0	13,0	17,0	17,0	24	10	0,85
50825601383	13	25,0	13,0	18,0	18,0	27	10	0,85
50825601483	14	25,0	14,0	19,5	19,5	34	10	0,95
50825601583	15	25,0	15,0	21,5	21,5	52	10	1,05

50825-6

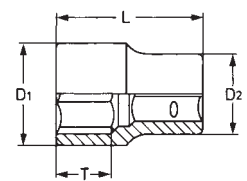

LLAVES DE VASO, EXTRA-LARGAS

DOUILLES, EXTRA LONGUES

SOCKETS, EXTRA DEEP

STECKSCHLÜSSELEINSÄTZE, EXTRA LANG
DIN 3124 / ISO 2725

Cromo Vanadio, cromadas

Chrome-Vanadium, chromées

Chrome-Vanadium, chromium plated

Chrom-Vanadium, verchromt

Bestell-No. Order-No.	ØMM	CLØ mm	T mm	D1 mm	D2 mm	g	mm	€
50825190683	6	50,0	12,0	10,0	12,0	22	10	1,25
50825190783	7	50,0	19,0	10,5	12,0	23	10	1,25
50825190883	8	50,0	19,0	12,0	12,0	25	10	1,25
50825190983	9	50,0	19,0	13,0	12,0	29	10	1,25
50825191083	10	50,0	21,0	14,5	13,0	35	10	1,30
50825191183	11	50,0	23,0	16,0	14,0	42	10	1,35
50825191283	12	50,0	23,0	17,0	15,0	45	10	1,40
50825191383	13	50,0	23,0	18,0	16,0	52	10	1,40
50825191483	14	50,0	23,0	19,0	17,0	55	10	1,50

50825-19

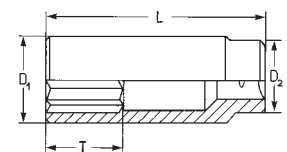

LLAVES DE VASO PARA TORNILLOS
TORX® EXTERIORES

DOUILLES POUR VIS
TORX® EXTERIEURES

SOCKETS FOR
TORX®-HEAD SCREWS

STECKSCHLÜSSELEINSÄTZE
FÜR AUßEN-TORX®-SCHRAUBEN

Cromo Vanadio, cromadas

Chrome-Vanadium, chromées

Chrome-Vanadium, chromium plated

Chrom-Vanadium, verchromt

Bestell-No. Order-No.	E	mm	CLØ mm	T mm	D1 mm	D2 mm	g	mm	€
50825200483	4	3,86	25,0	7,0	7,0	12,0	10	10	1,25
50825200583	5	4,75	25,0	7,0	8,0	12,0	10	10	1,25
50825200683	6	5,74	25,0	7,0	9,0	12,0	11	10	1,25
50825200783	7	6,22	25,0	12,0	11,0	12,0	12	10	1,25
50825200883	8	7,52	25,0	12,0	12,0	12,0	13	10	1,25
50825201083	10	9,42	25,0	12,0	14,0	14,0	15	10	1,40
50825201183	11	10,08	25,0	12,0	16,0	16,0	19	10	1,40

50825-20

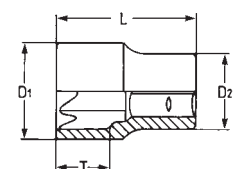

Schraubendrehereinsätze

Screwdriver Sockets

Douilles tournevis

Llaves de vaso con destornillador

Chrom-Vanadium, verchromt

Chrome-Vanadium, chromium plated

Chrome-Vanadium, chromées

Cromo Vanadio, cromadas

50825-30 – 50825-37

1/4"

1/4"

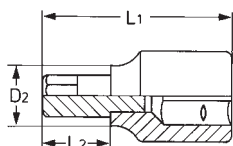

50825-30



50825-31



50825-32



50825-33



XZN



50825-35



50825-37



Bestell-No. Order-No.	Art.Nr.			L1 mm	L1 mm	D2 mm			€
50825300383	50825-30	4,0	0,7	36,0	18,0	12,0	15	10	0,90
50825300483	50825-30	5,5	0,9	36,0	18,0	12,0	15	10	0,90
50825300583	50825-30	7,0	1,0	36,0	18,0	12,0	15	10	0,90

Bestell-No. Order-No.	Art.Nr.		MM	L1 mm	L1 mm	D2 mm			€
50825310183	50825-31	3		36,0	17,0	12,0	15	10	0,90
50825310283	50825-31	4		36,0	17,0	12,0	15	10	0,90
50825310383	50825-31	5		36,0	17,0	12,0	15	10	0,90
50825310483	50825-31	6		36,0	17,0	12,0	15	10	0,90

Bestell-No. Order-No.	Art.Nr.			L1 mm	L1 mm	D2 mm			€
50825320183	50825-32	PH 1		36,0	17,0	12,0	15	10	0,90
50825320283	50825-32	PH 2		36,0	17,0	12,0	15	10	0,90
50825320383	50825-32	PH 3		36,0	17,0	12,0	15	10	0,90

Bestell-No. Order-No.	Art.Nr.			L1 mm	L1 mm	D2 mm			€
50825330183	50825-33	M5		36,0	17,0	12,0	15	10	1,05
50825330283	50825-33	M6		36,0	17,0	12,0	15	10	1,05
50825330383	50825-33	M8		36,0	17,0	12,0	15	10	1,05

Bestell-No. Order-No.	Art.Nr.			L1 mm	L1 mm	D2 mm			€
50825350183	50825-35	PZ 1		36,0	17,0	12,0	15	10	1,05
50825350283	50825-35	PZ 2		36,0	17,0	12,0	15	10	1,05
50825350383	50825-35	PZ 3		36,0	17,0	12,0	15	10	1,05

Bestell-No. Order-No.	Art.Nr.			mm	L1 mm	L1 mm	D2 mm			€
50825370883	50825-37	TT 8	2,52		37,0	17,0	12,0	15	10	1,15
50825371083	50825-37	TT 10	2,68		37,0	17,0	12,0	15	10	1,15
50825371583	50825-37	TT 15	3,48		37,0	17,0	12,0	15	10	1,15
50825372083	50825-37	TT 20	3,75		37,0	17,0	12,0	15	10	1,15
50825372583	50825-37	TT 25	4,25		37,0	17,0	12,0	15	10	1,15
50825372783	50825-37	TT 27	5,00		37,0	17,0	12,0	15	10	1,15
50825373083	50825-37	TT 30	5,55		37,0	17,0	12,0	15	10	1,15
50825374083	50825-37	TT 40	6,50		37,0	17,0	12,0	15	10	1,15

Accesorios

Accessoires

Accessories

Antriebs- und Verbindungsteile

3/8"

Cromo Vanadio, cromadas

Chrome-Vanadium, chromées

Chrome-Vanadium, chromium plated

Chrom-Vanadium, verchromt

50840-00-15 – 50840-06



50840-10-15



50840-03



50840-00-15



50850-14-1



50840-04



50840-04-1



50840-06



50840-14 / 50840-15

Carraca reversible

con expulsor para separación instantánea de vasos y accesorios

50840-00-15

Con mango ergonómico de dos componentes.
DIN 3122 D · ISO 3315

Cliquets réversibles

tige d'éjection pour libérer rapidement l'outil du cliquet

50840-00-15

Avec poignée ergonomique à 2 composants
DIN 3122 D · ISO 3315

Lever type reversible ratchet

with quick release ejector button

50840-00-15

with ergonomic 2 components handle
DIN 3122 D · ISO 3315

50840-10-15

Mango acodado, plastificado
DIN 3123 B · ISO 3316

50840-10-15

Poignée en acier déporté à enrobage plastique
DIN 3123 B · ISO 3316

50840-10-15

Offset handle, plastic coated
DIN 3123 B · ISO 3316

50840-03 · Mango corredizo
DIN 3122 A · ISO 3315

50840-03 · Poignée coulissante
DIN 3122 A · ISO 3315

50840-03 · Sliding T-handle
DIN 3122 A · ISO 3315

50850-14-1
Conexión corrediza para adaptador
DIN 3123 A · ISO 3316

50850-14-1
Coulisseau à adapter
DIN 3123 A · ISO 3316

50850-14-1
Sliding T-head / Adapter
DIN 3123 A · ISO 3316

50840-04-1/04 · Alargaderas
DIN 3123 B · ISO 3316

50840-04-1/04 · Rallonges
DIN 3123 B · ISO 3316

50840-04-1/04 · Extension bars
DIN 3123 B · ISO 3316

50840-06 · Articulación universal
DIN 3123 C · ISO 3316

50840-06 · Cardan universel
DIN 3123 C · ISO 3316

50840-06 · Universal joints
DIN 3123 C · ISO 3316

50840-14 · Reductor
50840-15 · Reductor
DIN 3123 A · ISO 3316

50840-14 · Réducteur
50840-15 · Réducteur
DIN 3123 A · ISO 3316

50840-14 · Converter
50840-15 · Converter
DIN 3123 A · ISO 3316

Hebelumschaliknarren
mit Auswerferstift zum Schnellösen der Steckverbindung

50840-00-15
mit ergonomischem 2-K Griff
DIN 3122 D · ISO 3315

50840-10-15
Gebogener Stahlkern, kunststoffummantelt
DIN 3123 B · ISO 3316

50840-03 · Griffe mit Gleitstück
DIN 3122 A · ISO 3315

50850-14-1
Gleitstücke für Verlängerung
DIN 3123 A · ISO 3316

50840-04-1/04 · Verlängerungen
DIN 3123 B · ISO 3316

50840-06 · Kardangelenke
DIN 3123 C · ISO 3316

50840-14 · Adapter
50840-15 · Adapter
DIN 3123 A · ISO 3316

Bestell-No. Order-No.	Art.No.	○	■	CLD mm	g	mm	€
50840015083	50840-00-15	3/8"		205	285	5	18,80
50840101500	50840-10-15	3/8"		195	205	5	22,60
50840030083	50840-03	3/8"		150	205	10	6,15
50850141083	50850-14-1	1/2"	3/8"	40	70	10	2,45
50840041083	50840-04-1	3/8"		75	75	10	1,50
50840040083	50840-04	3/8"		150	140	10	2,30
50840060083	50840-06	3/8"		55	65	10	4,70
50840140083	50840-14	3/8"	1/4"	25	68	10	2,10
50840150083	50840-15	3/8"	1/2"	45	70	10	2,55

Steckschlüsseinsätze, Sechskant
DIN 3124 / ISO 2725

Sockets, hexagon

Douilles, 6 pans

Llaves de vaso,
boca hexagonal

Chrom-Vanadium, verchromt

Chrome-Vanadium, chromium plated

Chrome-Vanadium, chromées

Cromo Vanadio, cromadas

50840-6

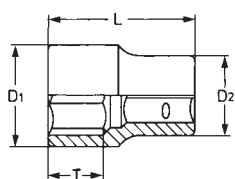

Bestell-No. Order-No.	ØMM	CL mm	T mm	D1 mm	D2 mm	g	mm	€
50840600883	8	25,5	10,0	12,5	12,0	20	10	0,90
50840600983	9	28,0	10,0	17,0	13,0	22	10	0,90
50840601083	10	28,0	12,0	14,5	17,0	23	10	0,90
50840601183	11	25,5	12,0	15,5	17,0	24	10	0,90
50840601283	12	25,5	10,0	17,0	17,0	25	10	0,90
50840601383	13	25,5	11,0	18,5	17,0	26	10	0,90
50840601483	14	25,5	15,0	20,0	18,0	30	10	1,05
50840601583	15	25,5	15,0	21,0	19,5	33	10	1,05
50840601683	16	25,5	16,0	22,0	19,5	34	10	1,25
50840601783	17	25,5	17,0	23,0	20,0	35	10	1,25
50840601883	18	26,0	17,0	24,5	21,0	40	10	1,45
50840601983	19	26,5	17,0	26,0	23,0	46	10	1,45
50840602083	20	32,0	18,0	27,0	24,0	68	10	1,65
50840602183	21	32,0	18,0	28,0	25,0	70	10	1,65
50840602283	22	32,0	18,0	29,5	26,5	82	10	1,65
50840602483	24	32,0	18,0	32,0	28,0	95	10	1,90

Zündkerzeneinsätze
DIN 3124 / ISO 2725

Spark Plug Sockets

Douilles pour bougies

Llaves de vaso, para bujías

Chrom-Vanadium, verchromt
mit GummisicherungChrome-Vanadium, chromium plated
with rubber insertChrome-Vanadium, chromées
avec bague de caoutchoucCromo Vanadio, cromadas
con injerto de goma

50840-19-1 · 50840-19-3

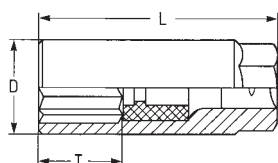

Bestell-No. Order-No.	ØMM	CL mm	T mm	D mm	ØMM	g	mm	€
50840190183	20,8	70,0	25,0	32,0	24	160	10	2,45
50840190383	16	65,0	20,0	22,5	19	100	10	1,95

Einsätze mit Schon-Profil und
KreuzrändelungSockets with SP-profile and
cross knurlingDouilles avec profil de protec-
tion et moletage en croixLlaves de vaso con perfil espe-
cial SP y grafilado cruzado

Super-Oberflächen-Verarbeitung,
Oberfläche in Matt-Finish.
Mehr Grip durch Kreuzrändelung.
Schon-Profil schützt Schrauben und
Muttern.

Superior surface appearance in mat
chromium plated finish
Cross knurling provides better grip
and SP profile
protects screws and nuts

Parfaite finition des surfaces,
Surfaces en finition mat,
Meilleur contact grâce au moletage
en croix, Le profil spécial protège les
boulons et écrous

Pulido perfecto de la superficie.
Acabado mate. Mayor agarre
gracias al grafilado cruzado.
El perfil especial SP reduce el
desgaste de tornillos y tuercas.



Accesorios

Accessoires

Accessories

Antriebs- und Verbindungsteile

1/2"

Cromo Vanadio, cromadas

Chrome-Vanadium, chromées

Chrome-Vanadium, chromium plated

Chrom-Vanadium, verchromt

50850-00-15 – 50850-06

1/2"
1/2"



50850-10-15



50850-03



50850-00-15



50840-15



50850-05



50850-04



50850-14-1



50850-05-5



50850-04-5



50850-06

Carraca reversible
con expulsor para separación instantánea de vasos y accesorios

Cliquets réversibles
tige d'éjection pour libérer rapidement l'outil du cliquet

Lever type reversible ratchet
with quick release ejector button

Hebelumschaltknarren
mit Auswerferstift zum Schnelllösen der Steckverbindung

50850-00-15
Con mango ergonómico de dos componentes.
DIN 3122 D · ISO 3315

50850-00-15
Avec poignée ergonomique à 2 composantes
DIN 3122 D · ISO 3315

50850-00-15
with ergonomic 2 components handle
DIN 3122 D · ISO 3315

50850-00-15
mit ergonomischem 2-K Griff
DIN 3122 D · ISO 3315

50850-10-15
Mango acodado, plastificado
DIN 3123 B · ISO 3316

50850-10-15
Poignée en acier déporté à enrobage plastique
DIN 3123 B · ISO 3316

50850-10-15
Offset handle, plastic coated
DIN 3123 B · ISO 3316

50850-10-15
Gebogener Stahlkern, kunststoffummantelt
DIN 3123 B · ISO 3316

50850-03 · Mango corredizo
DIN 3122 A · ISO 3315

50850-03 · Poignée coulissante
DIN 3122 A · ISO 3315

50850-03 · Sliding T-handle
DIN 3122 A · ISO 3315

50850-03 · Griffe mit Gleitstück
DIN 3122 A · ISO 3315

50850-04/05 · Alargaderas
DIN 3123 B · ISO 3316

50850-04/05 · Rallonges
DIN 3123 B · ISO 3316

50850-04/05 · Extension bars
DIN 3123 B · ISO 3316

50850-04/05 · Verlängerungen
DIN 3123 B · ISO 3316

50850-04-5/05-5
Alargaderas oscilante

50850-04-5/05-5
Rallonges articulée

50850-04-5/05-5
Wobble extension

50850-04-5/05-5
Schwenkbare Verlängerungen

50840-15/50850-14-1
Conexión corrediza para adaptador
DIN 3123 A · ISO 3316

50840-15/50850-14-1
Coulisseau à adapter,
DIN 3123 A · ISO 3316

50840-15/50850-14-1
Sliding T-head / Adapter
DIN 3123 A · ISO 3316

50840-15/50850-14-1
Gleitstücke für Verlängerung
DIN 3123 A · ISO 3316

50850-06 · Articulación universal
DIN 3123 C · ISO 3316

50850-06 · Cardan universel
DIN 3123 C · ISO 3316

50850-06 · Universal joints
DIN 3123 C · ISO 3316

50850-06 · Kardangelenke
DIN 3123 C · ISO 3316

Bestell-No. Order-No.	Art.No.	○	■	CL mm	g	g	€
50850015083	50850-00-15	1/2"		250	555	5	26,00
50850101500	50850-10-15	1/2"		250	450	5	26,90
50850030083	50850-03	1/2"		250	500	10	8,30
50840150083	50840-15	3/8"	1/2"	45	70	10	2,55
50850040083	50850-04	1/2"		125	200	10	3,35
50850045083	50850-04-5	1/2"		125	200	10	6,30
50850050083	50850-05	1/2"		250	420	10	5,75
50850055083	50850-05-5	1/2"		250	420	10	10,00
50850060083	50850-06	1/2"		75	150	10	6,05
50850141083	50850-14-1	1/2"	3/8"	40	70	10	2,45

Kombi-Hebelumschaltknarre und Verlängerung mit Durchsteckfunktion, Vierkantadapter

Lever type reversible ratchet and extension with go-through function, adapter for standard function

Cliquet réversible combiné et rallonge avec fonction traversante, adaptateur carré

Carraca reversible combinada y alargadera con accionamiento pasante, adaptador de cuadrado

Chrom-Vanadium, verchromt

Chrome-Vanadium, chromium plated

Chrome-Vanadium, chromées

Cromo Vanadio, cromadas

50855-00-15 – 50855-16

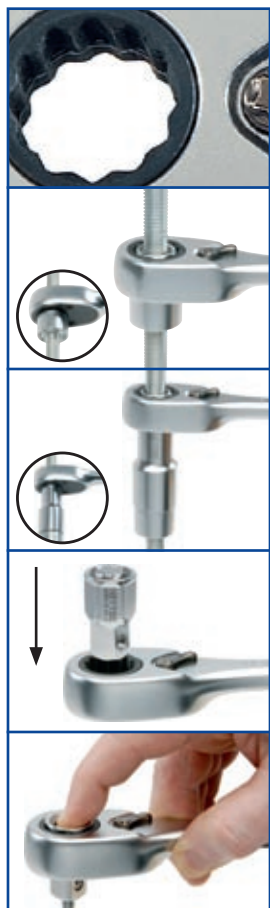

Verlängerungen
Extension bars
Rallonges
Alargaderas

Adapter für
Standardfunktionen
Adapter for
standard function
Adaptateur pour
fonctions standard
Adaptadores para
funciones standard

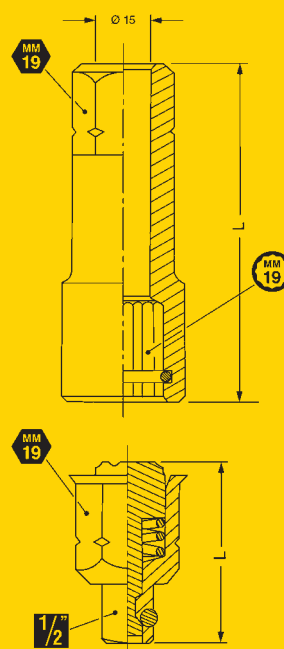

Bestell-No. Order-No.	Art.No.	℄ mm	g		€
50855015083	50855-00-15	260	495	1	32,00
50855041083	50855-04-1	75	130	1	5,60
50855160083	50855-16	37	61	1	7,10

Steckschlüsseleinsätze, sechskant mit Durchsteckfunktion

Sockets, hexagon with go-through function

Douilles, 6 pans avec fonction traversante

Llaves de vaso, boca exagonal, con accionamiento pasante

Chrom-Vanadium, verchromt

Chrome-Vanadium, chromium plated

Chrome-Vanadium, chromées

Cromo Vanadio, cromadas

50855-6

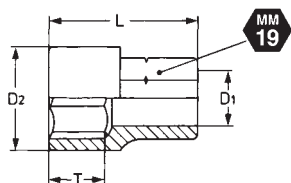

Bestell-No. Order-No.	MM	℄ mm	T mm	D1 mm	D2 mm	g		€
50855601083	10	38,0	15,0	9,0	15,0	46	10	2,80
50855601183	11	38,0	15,0	9,0	16,0	48	10	2,80
50855601283	12	38,0	15,0	11,0	18,0	48	10	2,80
50855601383	13	38,0	15,0	11,0	19,0	50	10	2,80
50855601483	14	38,0	15,0	12,0	20,0	53	10	3,00
50855601583	15	38,0	15,0	12,0	22,0	55	10	3,00
50855601783	17	38,0	16,0	14,0	24,0	52	10	3,10
50855601983	19	38,0	16,0	15,0	26,0	48	10	3,20
50855602183	21	38,0	16,0	15,0	28,0	50	10	3,30
50855602283	22	38,0	16,0	15,0	30,0	59	10	3,40
50855602483	24	38,0	16,0	15,0	32,0	62	10	3,50

Llaves de vaso,
boca hexagonal

Douilles, 6 pans

Sockets, hexagon

Steckschlüsseleinsätze, Sechskant
DIN 3124 / ISO 2725

Cromo Vanadio, cromadas

Chrome-Vanadium, chromées

Chrome-Vanadium, chromium plated

Chrom-Vanadium, verchromt

50850-6

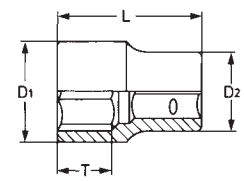

Bestell-No. Order-No.	MM	CL mm	T mm	D1 mm	D2 mm	g		€
50850600883	8	38,5	14,0	13,5	22,0	48	10	1,35
50850600983	9	38,5	14,0	14,5	22,0	48	10	1,35
50850601083	10	38,5	14,0	15,5	22,0	54	10	1,35
50850601183	11	38,5	14,0	16,5	22,0	51	10	1,35
50850601283	12	38,5	14,0	17,5	22,0	50	10	1,35
50850601383	13	38,5	14,0	18,5	22,0	50	10	1,35
50850601483	14	38,5	14,0	20,0	22,0	53	10	1,35
50850601583	15	38,5	14,0	21,5	22,0	55	10	1,65
50850601683	16	38,5	14,0	22,5	22,0	63	10	1,65
50850601783	17	38,5	14,0	24,0	22,5	66	10	1,65
50850601883	18	38,5	14,0	25,0	23,0	71	10	1,80
50850601983	19	38,5	20,0	25,0	24,5	74	10	1,80
50850602083	20	38,5	20,0	28,0	25,5	84	10	1,85
50850602183	21	38,5	20,0	28,0	26,5	84	10	1,85
50850602283	22	38,5	20,0	30,0	28,0	105	10	2,10
50850602383	23	40,0	20,0	32,0	28,0	116	10	2,10
50850602483	24	40,5	22,0	32,0	30,0	120	10	2,60
50850602783	27	42,5	22,0	36,0	34,0	170	10	3,15
50850603083	30	42,5	22,0	40,0	36,5	205	10	3,65
50850603283	32	45,0	25,0	42,0	38,0	235	10	3,90

Llaves de vaso,
extra largas

Douilles,
extra longues

Sockets,
extra deep

Steckschlüsseleinsätze, extra lang
DIN 3124 / ISO 2725

Cromo Vanadio, cromadas

Chrome-Vanadium, chromées

Chrome-Vanadium, chromium plated

Chrom-Vanadium, verchromt

50850-19

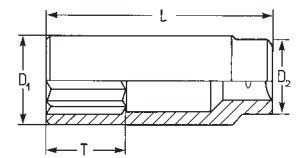

Bestell-No. Order-No.	MM	CL mm	T mm	D1 mm	D2 mm	g		€
50850191083	10	77,0	35,0	14,8	22,0	86	10	2,60
50850191383	13	77,0	35,0	18,8	22,0	105	10	2,80
50850191483	14	77,0	35,0	20,5	22,0	105	10	2,80
50850191583	15	77,0	35,0	22,0	22,0	115	10	2,80
50850191783	17	77,0	35,0	24,0	22,0	130	10	2,85
50850191983	19	77,0	35,0	26,0	23,0	145	10	3,15
50850192283	22	77,0	35,0	26,0	24,0	160	10	3,40
50850192483	24	77,0	35,0	28,0	24,0	170	10	3,80

Llaves de vaso, para bujías

Douilles pour bougies

Spark Plug Sockets

Zündkerzeneinsätze
DIN 3124 / ISO 2725

Cromo Vanadio, cromadas
con injerto de goma

Chrome-Vanadium, chromées
avec bague de caoutchouc

Chrome-Vanadium, chromium plated
with rubber insert

Chrom-Vanadium, verchromt
mit Gummisicherung

50850-19-1 • 50850-19-3

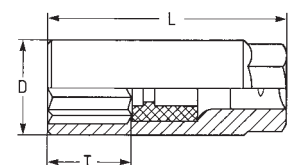

Bestell-No. Order-No.	Art.No.	MM	CL mm	T mm	D1 mm	MM	g		€
50850190183	50850-19-1	20,8	70,0	21,5	28,0	24,0	170	10	2,60
50850190383	50850-19-3	16,0	65,0	18,0	23,0	21,0	110	10	1,95



Steckschlüsseleinsätze
für Außen-TORX®-Schrauben

Chrom-Vanadium, verchromt

50850-20

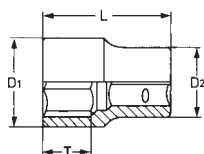
Sockets for
TORX®-head screws

Chrome-Vanadium, chromium plated

Douilles pour
TORX® extérieures

Chrome-Vanadium, chromées

Llaves de vaso para
tornillos TORX® exteriores

Cromo Vanadio, cromadas

Bestell-No. Order-No.	E	mm	mm	T mm	D1 mm	D2 mm	g		€
50850201083	E 10	9,42	38,0	14,0	15,0	22,0	53	10	2,60
50850201183	E 11	10,08	38,0	14,0	15,0	22,0	53	10	2,60
50850201283	E 12	11,17	38,0	14,0	15,0	22,0	53	10	2,60
50850201483	E 14	12,90	38,0	14,0	17,0	22,0	55	10	2,60
50850201683	E 16	14,76	38,0	14,0	19,0	22,0	55	10	2,60
50850201883	E 18	16,70	38,0	14,0	21,0	24,0	73	10	2,70
50850202083	E 20	18,49	38,0	14,0	24,0	22,0	68	10	2,80
50850202283	E 22	20,32	38,0	14,0	26,0	23,0	80	10	2,80
50850202483	E 24	22,16	38,0	14,0	28,0	24,0	96	10	2,95

Schraubendrehereinsätze

Chrom-Vanadium, verchromt

50850-31 • 50850-33

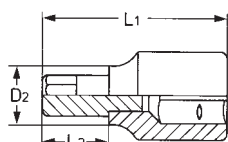

50850-31

Screwdriver Sockets

Chrome-Vanadium, chromium plated

Douilles tournevis

Chrome-Vanadium, chromées

Llaves de vaso con
destornillador

Cromo Vanadio, cromadas

Bestell-No. Order-No.	Art.Nr.	MM	L1 mm	L2 mm	D2 mm	g		€
50850310083	50850-31-0	4	62,0	24,0	18,0	85	10	2,30
50850311383	50850-31-13	4	138,0	100,0	18,0	118	5	3,20
50850310283	50850-31-2	5	62,0	24,0	18,0	87	10	2,30
50850311483	50850-31-14	5	138,0	100,0	18,0	118	5	3,20
50850310383	50850-31-3	6	62,0	24,0	18,0	88	10	2,30
50850312283	50850-31-22	6	100,0	62,0	18,0	105	5	3,10
50850311583	50850-31-15	6	138,0	100,0	18,0	118	5	3,20
50850310183	50850-31-1	7	62,0	24,0	18,0	90	10	2,30
50850311683	50850-31-16	7	138,0	100,0	18,0	120	5	3,20
50850310483	50850-31-4	8	62,0	24,0	18,0	90	10	2,30
50850312483	50850-31-24	8	100,0	62,0	18,0	107	5	3,10
50850311283	50850-31-12	8	138,0	100,0	18,0	122	5	3,20
50850310583	50850-31-5	10	62,0	24,0	18,0	93	10	2,45
50850312583	50850-31-25	10	100,0	62,0	18,0	120	5	3,50
50850311183	50850-31-11	10	138,0	100,0	18,0	144	5	3,80
50850310683	50850-31-6	12	62,0	24,0	20,0	102	10	2,60
50850312683	50850-31-26	12	100,0	62,0	20,0	142	5	3,90
50850311883	50850-31-18	12	138,0	100,0	20,0	175	5	4,45
50850310783	50850-31-7	14	62,0	24,0	22,0	120	10	2,80
50850312783	50850-31-27	14	100,0	62,0	22,0	173	5	4,40
50850311783	50850-31-17	14	138,0	100,0	22,0	217	5	5,50
50850310883	50850-31-8	17	62,0	24,0	26,0	158	10	3,60
50850311083	50850-31-10	17	138,0	100,0	26,0	305	5	7,30
50850310983	50850-31-9	19	62,0	24,0	26,0	168	10	3,90
50850311983	50850-31-19	19	138,0	100,0	26,0	350	5	8,60

Bestell-No. Order-No.	Art.Nr.	mm	L1 mm	L2 mm	D2 mm	g		€
50850330183	50850-33-1	M 5	62,0	24,0	18,0	86	10	2,95
50850332183	50850-33-21	M 5	138,0	100,0	18,0	118	5	4,30
50850330283	50850-33-2	M 6	62,0	24,0	18,0	88	10	2,95
50850331283	50850-33-12	M 6	100,0	62,0	18,0	102	5	3,20
50850332283	50850-33-22	M 6	138,0	100,0	18,0	118	5	4,30
50850330383	50850-33-3	M 7	62,0	24,0	18,0	88	10	2,95
50850332383	50850-33-23	M 7	138,0	100,0	18,0	119	5	4,30
50850330483	50850-33-4	M 8	62,0	24,0	18,0	88	10	2,95
50850331483	50850-33-14	M 8	100,0	62,0	18,0	104	5	3,20
50850332483	50850-33-24	M 8	138,0	100,0	18,0	120	5	4,30
50850330583	50850-33-5	M 10	62,0	24,0	18,0	91	10	3,00
50850331583	50850-33-15	M 10	100,0	62,0	18,0	118	5	3,35
50850332583	50850-33-25	M 10	138,0	100,0	18,0	140	5	5,40
50850330683	50850-33-06	M 12	62,0	24,0	20,0	100	10	3,50
50850331683	50850-33-16	M 12	100,0	62,0	20,0	139	5	4,50
50850332683	50850-33-26	M 12	138,0	100,0	20,0	170	5	6,10
50850330783	50850-33-07	M 14	62,0	24,0	22,0	113	10	3,90
50850332783	50850-33-27	M 14	138,0	100,0	22,0	212	5	7,10



50850-33

Llaves de vaso con destornillador

Douilles tournevis

Screwdriver Sockets

Steckschlüsseinsätze

Cromo Vanadio, cromadas



Chrome-Vanadium, chromées





Chrome-Vanadium, chromium plated





Chrom-Vanadium, verchromt

50850-34 • 50850-36

50850-37

Bestell-No. Order-No.	Art.Nr.		L1 mm	L2 mm	D2 mm			€
50850340183	50850-34-1	M 5	62,0	24,0	18,0	87	10	3,30
50850342183	50850-34-21	M 5	138,0	100,0	18,0	118	5	4,70
50850340283	50850-34-2	M 6	62,0	24,0	18,0	88	10	3,30
50850342283	50850-34-22	M 6	138,0	100,0	18,0	119	5	4,70
50850340383	50850-34-3	M 7	62,0	24,0	18,0	88	10	3,30
50850342383	50850-34-23	M 7	138,0	100,0	18,0	119	5	4,70
50850340483	50850-34-4	M 8	62,0	24,0	18,0	89	10	3,30
50850342483	50850-34-24	M 8	138,0	100,0	18,0	119	5	4,70
50850340583	50850-34-5	M 10	62,0	24,0	18,0	91	10	3,40
50850342583	50850-34-25	M 10	138,0	100,0	18,0	141	5	4,90
50850340683	50850-34-06	M 12	62,0	24,0	20,0	101	10	4,30
50850342683	50850-34-26	M 12	138,0	100,0	20,0	173	5	6,40
50850340783	50850-34-07	M 14	62,0	24,0	22,0	114	10	5,25
50850342783	50850-34-27	M 14	138,0	100,0	22,0	212	5	7,40

Bestell-No. Order-No.	Art.Nr.		 mm	L1 mm	L2 mm	D2 mm			€
50850362083	50850-36-20	T 20	3,86	62,0	24,0	18,0	86	10	2,60
50850361083	50850-36-10	T 20	3,86	138,0	100,0	18,0	117	5	3,60
50850362583	50850-36-25	T 25	4,43	62,0	24,0	18,0	86	10	2,60
50850361183	50850-36-11	T 25	4,43	138,0	100,0	18,0	119	5	3,60
50850362783	50850-36-27	T 27	4,99	62,0	24,0	18,0	86	10	2,60
50850361283	50850-36-12	T 27	4,99	138,0	100,0	18,0	119	5	3,60
50850363083	50850-36-30	T 30	5,62	62,0	24,0	18,0	87	10	2,60
50850360383	50850-36-3	T 30	5,62	100,0	62,0	18,0	100	5	3,10
50850361383	50850-36-13	T 30	5,62	138,0	100,0	18,0	118	5	3,60
50850364083	50850-36-40	T 40	6,65	62,0	24,0	18,0	88	10	2,60
50850360483	50850-36-4	T 40	6,65	100,0	62,0	18,0	102	5	3,10
50850361483	50850-36-14	T 40	6,65	138,0	100,0	18,0	120	5	3,60
50850364583	50850-36-45	T 45	7,82	62,0	24,0	18,0	88	10	2,60
50850361583	50850-36-15	T 45	7,82	138,0	100,0	18,0	120	5	3,60
50850365083	50850-36-50	T 50	8,83	62,0	24,0	18,0	90	10	2,60
50850360683	50850-36-6	T 50	8,83	100,0	62,0	18,0	115	5	3,10
50850361683	50850-36-16	T 50	8,83	138,0	100,0	18,0	120	5	3,60
50850365583	50850-36-55	T 55	11,22	62,0	24,0	18,0	92	10	2,75
50850361783	50850-36-17	T 55	11,22	138,0	100,0	18,0	142	5	4,60
50850366083	50850-36-60	T 60	13,25	62,0	24,0	20,0	100	10	3,15
50850360883	50850-36-8	T 60	13,25	100,0	62,0	20,0	138	5	4,30
50850361883	50850-36-18	T 60	13,25	138,0	100,0	20,0	173	5	5,30
50850367083	50850-36-70	T 70	13,25	62,0	24,0	22,0	114	10	3,50
50850361983	50850-36-19	T 70	13,25	138,0	100,0	22,0	213	5	6,70

Bestell-No. Order-No.	Art.Nr.		 mm	L1 mm	L2 mm	D2 mm			€
50850372083	50850-37-20	TT 20	3,86	62,0	24,0	18,0	86	10	2,60
50850372583	50850-37-25	TT 25	4,43	62,0	24,0	18,0	86	10	2,60
50850372783	50850-37-27	TT 27	4,99	62,0	24,0	18,0	86	10	2,60
50850373083	50850-37-30	TT 30	5,62	62,0	24,0	18,0	86	10	2,60
50850374083	50850-37-40	TT 40	6,65	62,0	24,0	18,0	87	10	2,60
50850374583	50850-37-45	TT 45	7,82	62,0	24,0	18,0	88	10	2,60
50850375083	50850-37-50	TT 50	8,83	62,0	24,0	18,0	88	10	2,60
50850375583	50850-37-55	TT 55	11,22	62,0	24,0	18,0	90	10	2,85
50850376083	50850-37-60	TT 60	13,25	62,0	24,0	20,0	100	10	3,20

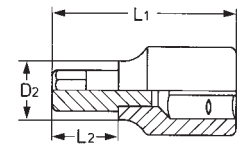

50850-34 RIBE



50850-36 TORX®



50850-37 Tamper TORX®

3/4"

Antriebs- und Verbindungsteile

Accessories

Accessoires

Accesorios

Chrom-Vanadium, verchromt

Chrome-Vanadium, chromium plated

Chrome-Vanadium, chromées

Cromo Vanadio, cromadas

508100-00-6 – 508100-05



508100-00-6



508100-03



508100-04



508100-04-1



508100-05

**508100-00-6
Umschaltknarre**

mit Druckbetätigung zum Schnelllösen
und zur Arretierung der Steckverbindung.
DIN 3122 D · ISO 3315

**508100-00-6
Lever type reversible ratchet**
with quick release ejector button
DIN 3122 D · ISO 3315**508100-00-6
Cliquets réversibles**
tige d'éjection pour libérer
rapidement l'outil du cliquet
DIN 3122 D · ISO 3315**508100-00-6
Carraca reversible**
con expulsor para separación
instantánea de vasos y accesorios
DIN 3122 D · ISO 3315**508100-03 · Griff mit Gleitstück**
DIN 3122 A · ISO 3315**508100-03 · Sliding T-handles**
DIN 3122 A · ISO 3315**508100-03 · Poignée coulissantes**
DIN 3123 B · ISO 3316**508100-03 · Mango corredizo**
DIN 3123 B · ISO 3316**508100-04/04-1/05
Verlängerungen**
DIN 3123 B · ISO 3316**508100-04/04-1/05
Extension bars**
DIN 3123 B · ISO 3316**508100-04/04-1/05
Rallonges**
DIN 3123 B · ISO 3316**508100-04/04-1/05
Alargaderas**
DIN 3123 B · ISO 3316

Bestell-No. Order-No.	Art.No.	□ ■	CLD mm	g	g	€
50810000680	508100-00-6	3/4"	510	1700	2	104,50
50810003080	508100-03	3/4"	455	1360	2	29,25
50810004180	508100-04-1	3/4"	100	440	2	15,70
50810004080	508100-04	3/4"	200	840	2	20,90
50810005080	508100-05	3/4"	400	1560	2	29,25

Llaves de vaso,
boca hexagonal

Douilles, 6 pans

Sockets, hexagon

Steckschlüsseinsätze, Sechskant
DIN 3124 / ISO 2725

Cromo Vanadio, cromadas

Chrome-Vanadium, chromées

Chrome-Vanadium, chromium plated

Chrom-Vanadium, verchromt

508100-6

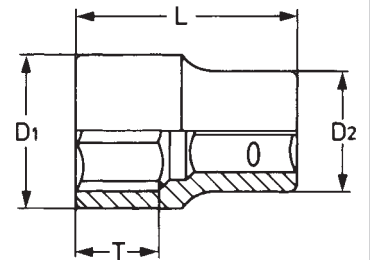

Bestell-No. Order-No.	MM	mm	T mm	D1 mm	D2 mm	g		€
50810061980	19	50	15	29	33	168	5	6,25
50810062180	21	50	15	31	33	172	5	6,25
50810062280	22	50	15	33	36	211	5	6,25
50810062380	23	50	15	33	36	211	5	6,25
50810062480	24	50	15	34	36	225	5	6,25
50810062680	26	52	26	37	36	223	5	6,55
50810062780	27	52	26	38	36	224	5	6,80
50810062980	29	52	26	40	38	262	5	7,15
50810063080	30	54	26	42	38	285	5	7,15
50810063280	32	56	28	44	38	305	5	8,35
50810063580	35	58	30	48	42	395	5	8,35
50810063680	36	58	30	50	42	434	5	10,45
50810063880	38	60	30	52	45	472	5	10,45
50810064180	41	64	36	56	45	550	5	11,25
50810064680	46	68	36	62	48	685	5	13,20
50810065080	50	72	40	68	48	800	5	14,80

Características especiales

Carraca con dentado fino.
Conexión corrediza, carraca y
alargaderas con expulsor rápido

Particularités

Cliquets à fine denture
Poignée coulissante, cliquet et
rallonges à éjection rapide

Features

Ratchet with fine toothing
Sliding Thread, ratchet and
extension bars with
quick release ejector button

Besonderheiten

Knarre mit Feinverzahnung.
Gleitstück, Knarre und Verlängerungen
mit Schnell-Auswurf.



Steckschlüsselgarnituren

Kombinierte Steckschlüssel-/
SchraubenschlüsselgarniturenSätze mit Schraubendreher-
einsätzen

Socket sets

Combined Sets of Sockets
and Wrenches

Sets with Screwdriver Sockets

Compositions de douilles

Jeux de douilles et clés de
serrage

Jeux de douilles-tournevis

Conjuntos de llaves de vaso

Conjuntos combinados de
llaves de vaso y planasJuegos de llaves de vaso con
punta de destornillador $1/4''$ 

25

 $3/8''$ 

26

 $1/2''$ 

27

33

 $3/4''$ 

34

Conjunto de llaves de vaso
44 pzs.

Compositions de douilles
44 pces.

Socket set
44 pcs.

Steckschlüsselgarnitur
44-tlg.

Cromo Vanadio, cromadas,
en caja de plástico

Chrome-Vanadium, chromées,
en coffret plastique

Chrome-Vanadium, chromium plated,
in plastic box

Chrom-Vanadium, verchromt,
in Kunststoffkoffer

Bestell-No. Order-No.	Art.No.	Maße · Dimensions · Medidas	g	Stk	€
50825301583	50825-3015	280 x 220 x 60 mm	1600	1	71,90

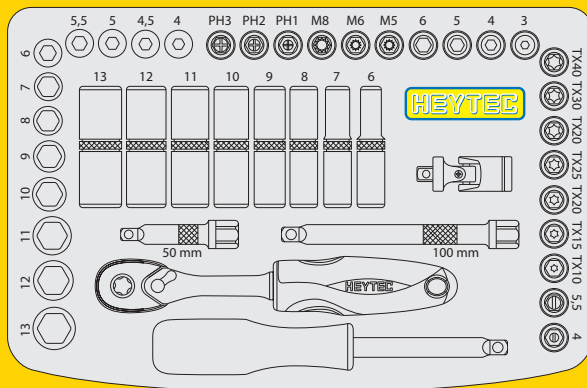

50825-3015

Conjunto de llaves de vaso
23 pzs.

Compositions de douilles
23 pces.

Socket set
23 pcs.

Steckschlüsselgarnitur
23-tlg.

Cromo Vanadio, cromadas,
en caja de plástico

Chrome-Vanadium, chromées,
en coffret plastique

Chrome-Vanadium, chromium plated,
in plastic box

Chrom-Vanadium, verchromt,
in Kunststoffbox

Bestell-No. Order-No.	Art.No.	enthaltend · containing composition · contenido	g	Stk	€
50828301083	50828-3010	4 · 4,5 · 5 · 5,5 · 6 · 7 · 8 9 · 10 · 11 · 12 · 13 Adapter · Converter Reducteur · Reductor 125 mm TT15 · TT20 · TT25 · TT30 PH 1 · PH 2 PZ 1 · PZ 2 95 mm	1600	1	48,00



50828-3010

Carraca mini, especialmente apta
para sitios de difícil acceso

Mini cliquet pour accès difficiles
ou restreints

Mini-ratchet is particular suitable
for restricted working areas

Mini-Knarre besonders geeignet für
schwer zugängliche Arbeitsbereiche

Conjunto de llaves de vaso
22 pzs.

Compositions de douilles
22 pces.

Socket set
22 pcs.

Steckschlüsselgarnitur
22-tlg.

Cromo Vanadio, cromadas,
en caja de plástico

Chrome-Vanadium, chromées,
en coffret plastique

Chrome-Vanadium, chromium plated,
in plastic box

Chrom-Vanadium, verchromt,
in Kunststoffbox

Bestell-No. Order-No.	Art.No.	Maße · Dimensions · Medidas	g	Stk	€
50829301783	50829-3017	160 x 102 x 36 mm	575	1	59,00

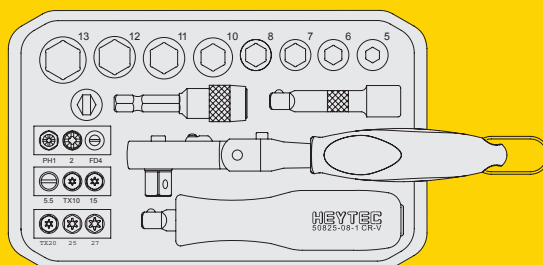



Mit arretierbarer Gelenknarre + Gürtelclip
With articulated lockable ratchet plus belt clip
Avec cliquet articulé blocable + adaptateur de ceinture
Con carraca articulada bloqueable más clip para el cinturón

50829-3017





NEW

Steckschlüsselgarnitur
23-tlg.Chrom-Vanadium, verchromt,
in Kunststoffkoffer**50840-3015**Socket set
23 pcs.Chrome-Vanadium, chromium plated,
in plastic boxCompositions de douilles
23 pcs.Chrome-Vanadium, chromées,
en coffret plastiqueConjunto de llaves de vaso
23 pzs.Cromo Vanadio, cromadas,
en caja de plástico

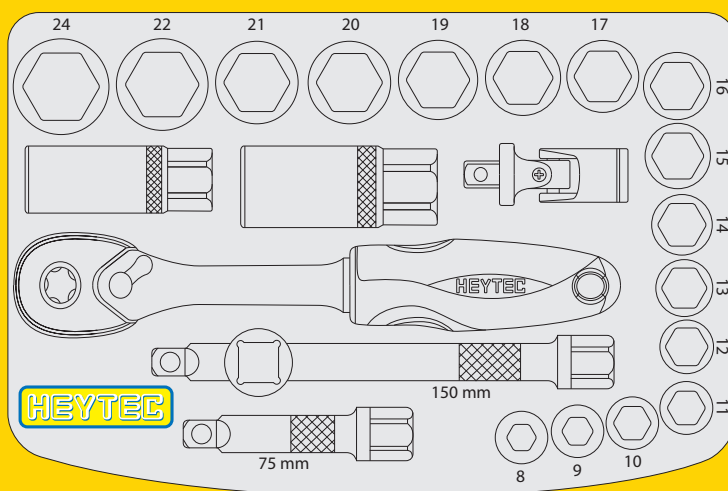
Bestell-No. Order-No.	Art.No.	Maße · Dimensions · Medidas			€
50840301583	50840-3015	280 x 220 x 60 mm	2000	1	72,10

Steckschlüsselgarnitur
15-tlg.Chrom-Vanadium, verchromt,
in Metallkasten**50843-3015**Socket set
15 pcs.Chrome-Vanadium, chromium plated,
in metal caseCompositions de douilles
15 pcs.Chrome-Vanadium, chromées,
en coffret métalliqueConjunto de llaves de vaso
15 pzs.Cromo Vanadio, cromadas,
en caja metálica

Bestell-No. Order-No.	Art.No.	Maße · Dimensions · Medidas			€
50843301583	50843-3015	225 x 115 x 40 mm	1230	1	59,00

enthaltend · containing
composition · contenidoMM 8 · 9 · 10 · 11
12 · 13 · 14 · 15
16 · 17 · 18 · 19

195 mm



125 mm



55 mm

Surtido de llaves de vaso con destornillador, 27 pzs.

Composition de douilles-tournevis, 27 pces.

Screwdriver socket set 27 pcs.

Schraubendrehereinsatz-Sortiment, 27-tlg.

Cromo vanadio, cromado, en caja de plástico, para tornillos TORX® macho y hembra,

Chrome-vanadium, chromées, en coffret plastique pour vis TORX® int et ext.

Chrome-Vanadium, chromium plated, in plastic box, for TORX® socket and head screws

Chrom-Vanadium, verchromt, für Innen- und Aussen-Torx®-Schrauben in Kunststoffkoffer

50850-52

Bestell-No. Order-No.	Art.No.	Maße · Dimensions · Medidas			€
50850520083	50850-52	350 x 280 x 80 mm	3615	1	125,00

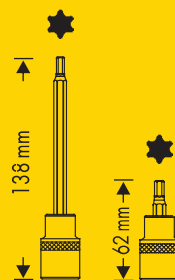
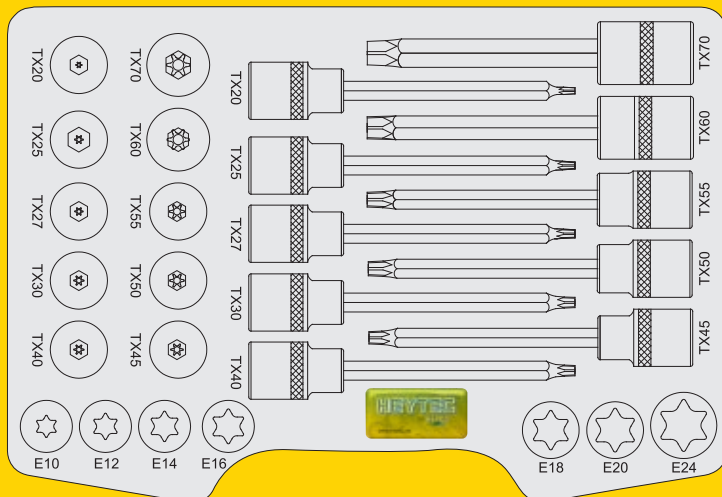

Surtido de llaves de vaso con destornillador, 20 pzs.

Composition de douilles-tournevis, 20 pces.

Screwdriver socket set 20 pcs.

Schraubendrehereinsatz-Sortiment, 20-tlg.

Cromo vanadio, cromado, en caja de plástico para tornillos Allen,

Chrome-vanadium, chromées, en coffret plastique pour vis hexagonales int.

Chrome-Vanadium, chromium plated, in plastic box, for hexagon socket screws

Chrom-Vanadium, verchromt, für Innensechskantschrauben in Kunststoffkoffer

50850-55

Bestell-No. Order-No.	Art.No.	Maße · Dimensions · Medidas			€
50850551283	50850-55	350 x 280 x 80 mm	3765	1	119,00

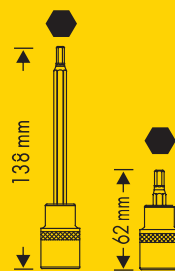
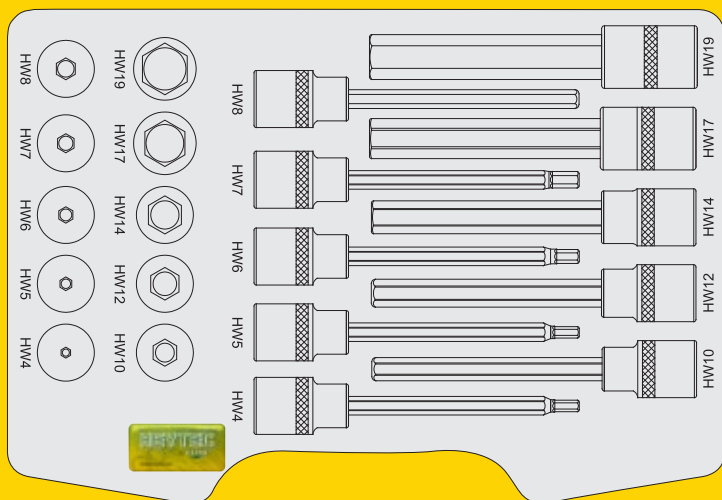

Schraubendrehereinsatz-Sortiment, 33-tlg.

Chrom-Vanadium, verchromt, in Kunststoffkoffer

50850-53

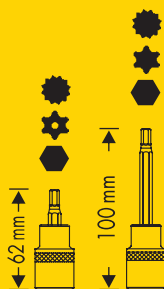

Bestell-No. Order-No.	Art.No.	Maße · Dimensions · Medidas			€
50850530083	50850-53	350 x 280 x 80 mm	4400	1	144,00

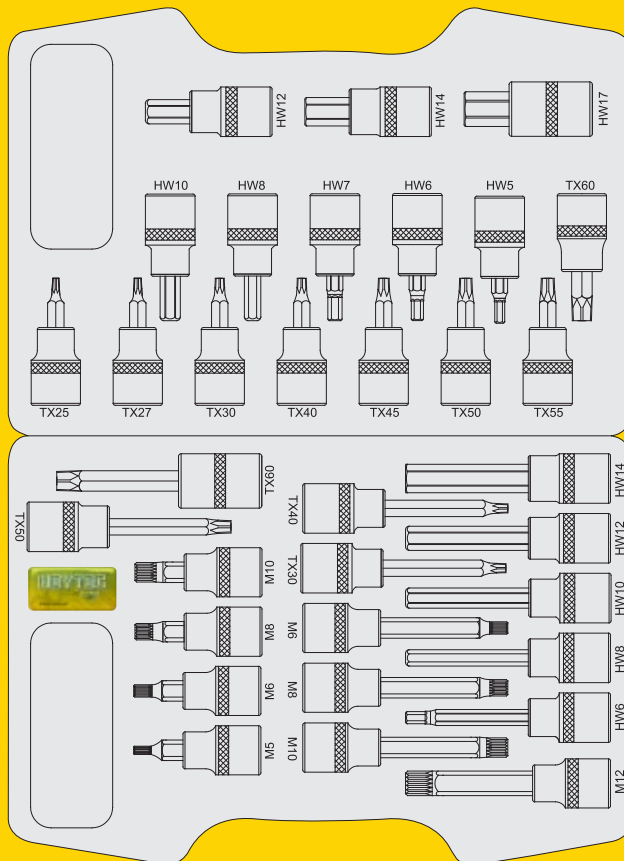

Schraubendrehereinsatz-Sortiment, 7-tlg.

Chrom-Vanadium, verchromt, in Metallkasten

50850-56



Screwdriver socket set 7 pcs.

Chrome-Vanadium, chromium plated, in metal case

Composition de douilles-tournevis, 7 pcs.

Chrome-Vanadium, chromées, en coffret métallique

Surtido de llaves de vaso con destornillador, 7 pzs.

Cromo vanadio, cromado, en caja de metal

Bestell-No. Order-No.	Art.No.	Maße · Dimensions · Medidas			€
50850560283	50850-56	250 x 135 x 40 mm	1570	1	54,00

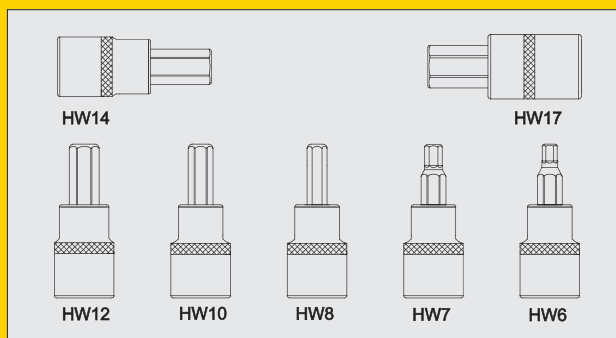

Surtido de llaves de vaso con destornillador, 28 pzs.

Composition de douilles-tournevis, 28 pces.

Screwdriver socket set 28 pcs.

Schraubendrehereinsatz-Sortiment, 28-tlg.

Cromo Vanadio, cromadas, en caja de plástico, para tornillos RIBE y XZN

Chrome-Vanadium, chromées, en coffret plastique, pour vis RIBE int. pour vis XZN int. multi-dents

Chrome-Vanadium, chromium plated, in plastic box, for fluted socket screws RIBE for multi-spline socket screws XZN

Chrom-Vanadium, verchromt, für Schrauben mit Innen-RIBE und Vielzahn XZN-Köpfen, in Kunststoffkoffer



Bestell-No. Order-No.	Art.No.	Maße · Dimensions · Medidas			€
50850540083	50850-54	350 x 280 x 80 mm	4230	1	147,00

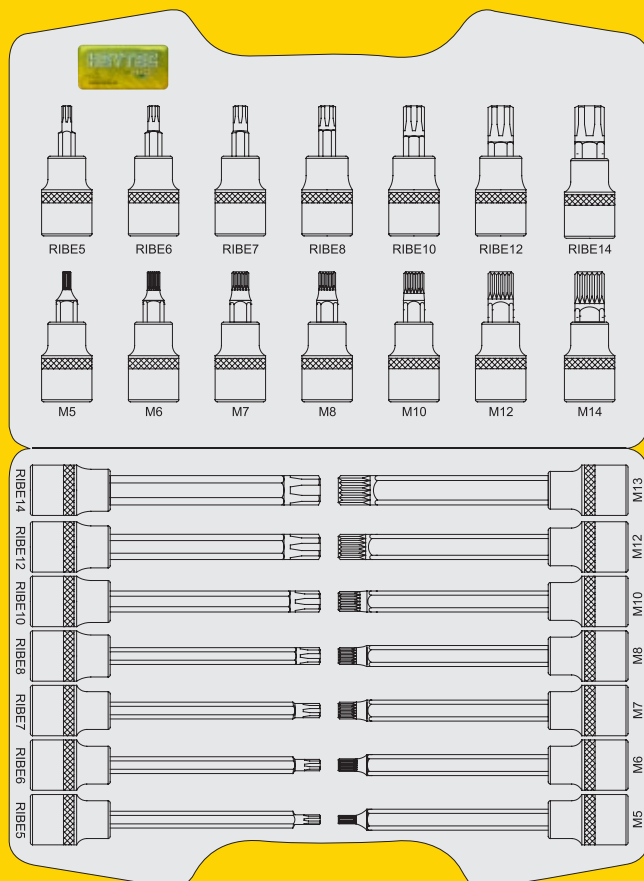

50850-54



Surtido de llaves de vaso con destornillador, 9 pzs.

Composition de douilles-tournevis, 9 pces.

Screwdriver socket set 9 pcs.

Schraubendrehereinsatz-Sortiment, 9-tlg.

Cromo vanadio, cromado, en caja de metal, para tornillos Tamper TORX®

Chrome-Vanadium, chromées, en coffret métallique, pour vis TORX® avec trou

Chrome-Vanadium, chromium plated, in metal case, for Tamper-TORX®-screws

Chrom-Vanadium, verchromt, im Metallkasten, für Tamper-TORX®-Schrauben



Bestell-No. Order-No.	Art.No.	Maße · Dimensions · Medidas			€
50850590083	50850-59	250 x 135 x 40 mm	1650	1	59,00

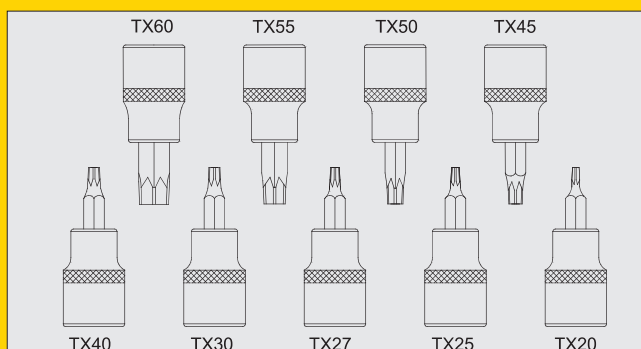

50850-59



Steckschlüsselgarnitur mit 4 in 1 Knarrenringschlüssel, 31-tlg.

Chrom-Vanadium, verchromt, in Kunststoffkoffer

50884-3015



Socket set with 4 in 1 ratcheting wrench, 31 pcs.

Chrome-Vanadium, chromium plated, in plastic box

Coffret de douilles avec clés polygonales à cliquet 4 en 1 31 pcs.

Chrome-Vanadium, chromées, en coffret plastique

Conjuntos de llaves de vaso con llave boca estrella de carraca „4 en 1“, 31 pzs.

Cromo vanadio, cromado, en caja de plástico

Bestell-No. Order-No.	Art.No.	Maße · Dimensions · Medidas			€
50884301583	50884-3015	350 x 280 x 80 mm	4980	1	289,00

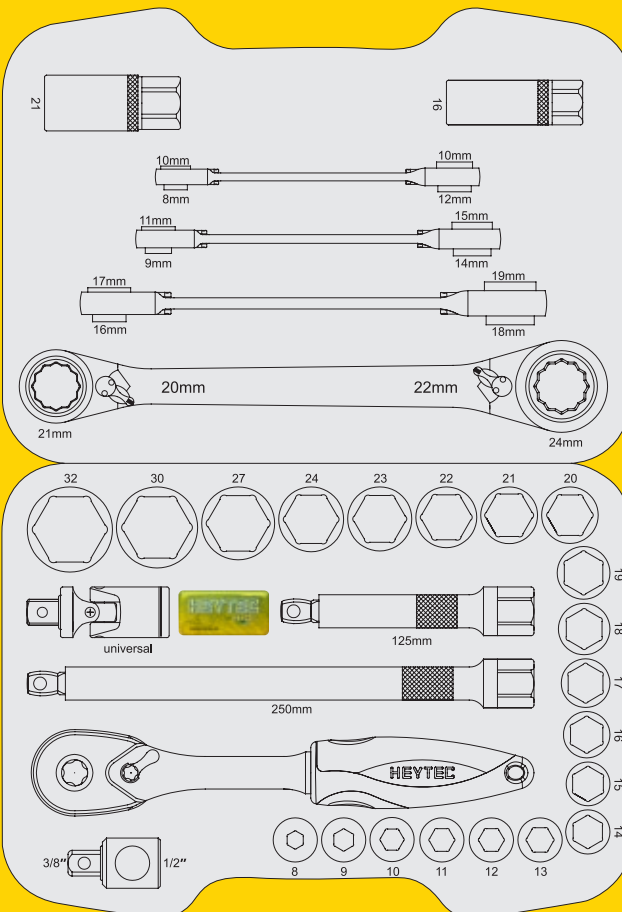

Universal-Steckschlüsselgarnitur mit Durchsteckfunktion, 14-tlg.

Chrom-Vanadium, verchromt, in Metallkasten

50855-3015

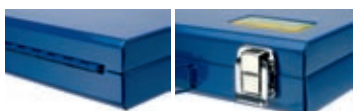

Universal socket set with go-through function, 14 pcs.

Chrome-Vanadium, chromium plated, in metal case

Coffret de douilles universelles avec fonction traversante, 14 pcs.

Chrome-Vanadium, chromées, en coffret métallique

Conjunto de llaves de vaso universal, con accionamiento pasante, 14 pzs.

Cromo Vanadio, cromadas, en caja de metal

Bestell-No. Order-No.	Art.No.	Maße · Dimensions · Medidas			€
50855301583	50855-3015	320 x 160 x 55 mm	2600	1	119,00

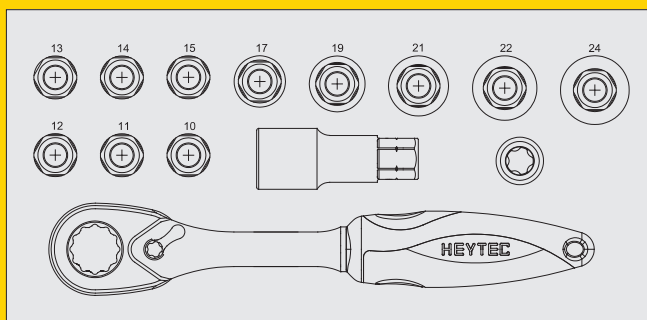

Conjunto de llaves de vaso
18 pzs.

Compositions de douilles
18 pces.

Socket set
18 pcs.

Steckschlüsselgarnitur
18-tlg.



Cromo Vanadio, cromadas,
en caja de plástico

Chrome-Vanadium, chromées,
en coffret plastique

Chrome-Vanadium, chromium plated,
in plastic box

Chrom-Vanadium, verchromt,
in Kunststoffkoffer

50851-3015

Bestell-No. Order-No.	Art.No.	Maße · Dimensions · Medidas			€
50851301583	50851-3015	350 x 280 x 80 mm	3500	1	82,55

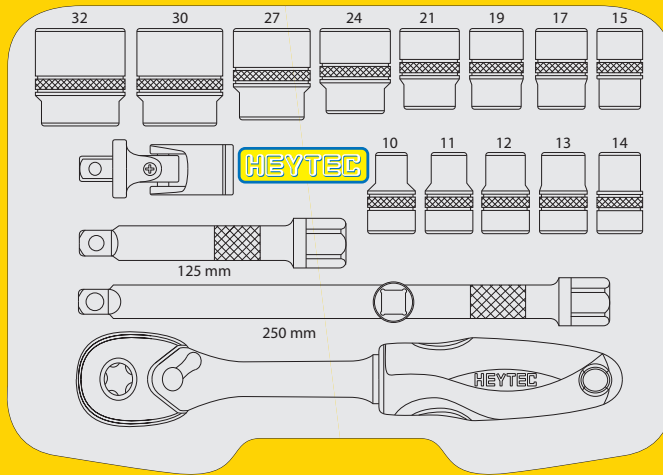

Conjunto de llaves de vaso
39 pzs.

Compositions de douilles
39 pces.

Socket set
39 pcs.

Steckschlüsselgarnitur
39-tlg.



Cromo Vanadio, cromadas,
en caja de plástico

Chrome-Vanadium, chromées,
en coffret plastique

Chrome-Vanadium, chromium plated,
in plastic box

Chrom-Vanadium, verchromt,
in Kunststoffkoffer

50853-3015

Bestell-No. Order-No.	Art.No.	Maße · Dimensions · Medidas			€
50853301583	50853-3015	350 x 280 x 80 mm	5500	1	131,65

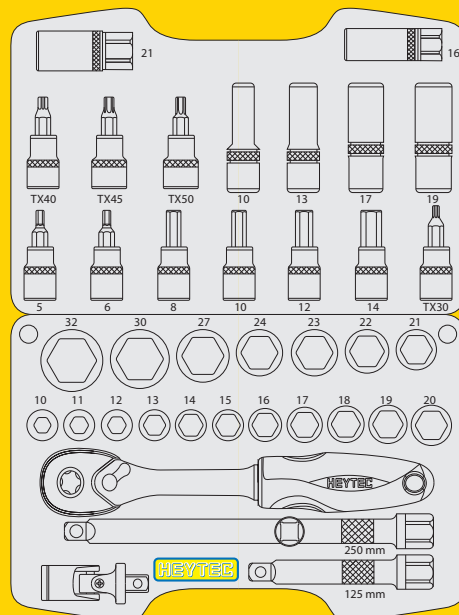

Steckschlüsselgarnitur
105-tlg.

Chrom-Vanadium, verchromt,
in Kunststoffkoffer

50825-5015



Heytec 104-teilige Steckschlüssel-Garnitur

Vertrieb: Heyco, Remscheid
 Preis: um 180 Euro
 Telefon: 0 21 91 / 2 00-0
 Internet: www.heyco.de

Bewertung: ★★★★★

• Preis mit Zubehör
 • Verlagerung mit Steckschlüsselhalter
 • Schraubentherapie

Note:

Funktion:	20%	1,3	★★★★★
Robuster:	20%	1,3	★★★★★
Überwachungskontrolle:	20%	1,2	★★★★
Bedienung:	10%	1,2	★★★★
Anschaffung:	10%	1,3	★★★★★

**Heimwerker
Praxis** Ausgabe 1/2010

1,3

Preis-Leistung: gut - sehr gut

Socket set
105 pcs.

Chrome-Vanadium, chromium plated,
in plastic box

Compositions de douilles
105 pcs.

Chrome-Vanadium, chromées,
en coffret plastique

Conjunto de llaves de vaso
105 pzs.

Cromo Vanadio, cromadas,
en estuche de polipropileno

Bestell-No. Order-No.	Art.No.	Maße · Dimensions · Medidas			€
50825501583	50825-5015	420 x 320 x 75 mm	6500	1	182,90

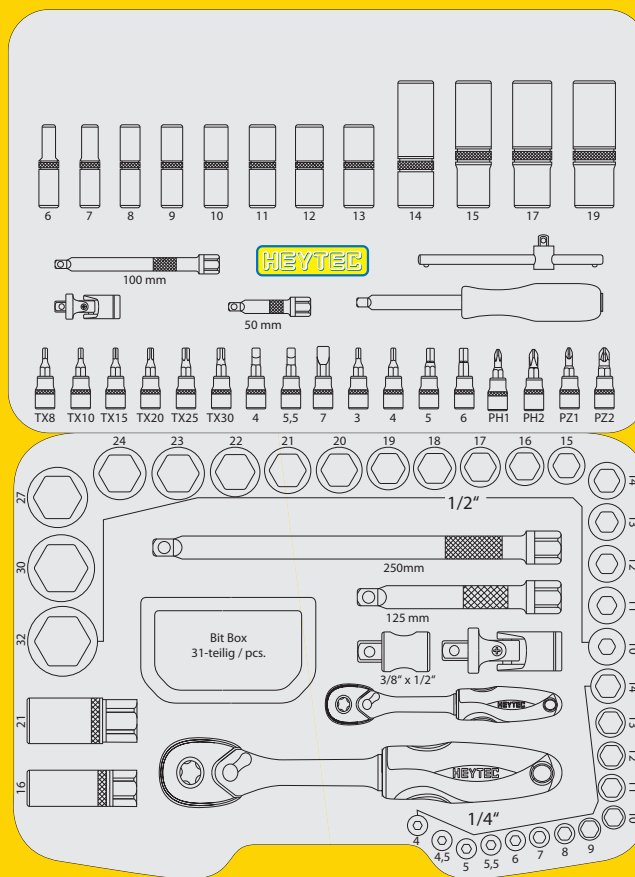

Kombinierte Steckschlüssel-
und Ringmaulschlüsselgarnitur,
33-tlg.

Chrom-Vanadium, verchromt,
in Metallkasten

50860-3015



Combined Set of Sockets
and combination Wrenches,
33 pcs.

Chrome-Vanadium, chromium plated,
in metal case

Composition de douilles et
cles mixtes, 33 pcs.

Chrome-Vanadium, chromées,
en coffret métallique

Juego combinados de
llaves de vaso y llaves
combinados, 33 pzs.

Cromo Vanadio, cromadas,
en caja metálica

Bestell-No. Order-No.	Art.No.	Maße · Dimensions · Medidas			€
50860301580	50860-3015	450 x 187 x 52 mm	5600	1	124,00

enthaltend · containing · composition · contenido

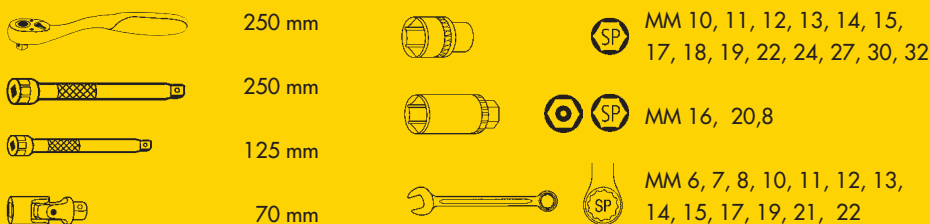

Conjunto de llaves de vaso
19*/21** pzs.

Compositions de douilles
19*/21** pces.

Socket set
19*/21** pcs.

Steckschlüsselgarnitur
19*/21**-tlg.

Cromo Vanadio, cromadas,
en caja metálica

Chrome-Vanadium, chromées,
en coffret métallique

Chrome-Vanadium, chromium plated,
in metal case

Chrom-Vanadium, verchromt,
in Metallkasten

Bestell-No. Order-No.	Art.No.*	Maße · Dimensions · Medidas			€
50872301583	50872-3015	407 x 162 x 52 mm	3910	1	119,00

enthaltend · containing · composition · contenido

	250 mm				MM 10, 11, 12, 13, 14, 15, 16, 17, 19, 22, 24, 27, 30, 32
	250 mm 125 mm				

Bestell-No. Order-No.	Art.No.**	Maße · Dimensions · Medidas			€
50873301583	50873-3015	407 x 162 x 52 mm	4130	1	124,00

enthaltend · containing · composition · contenido

wie · as · comme · como 50872-3015 + MM 16, 20,8



Conjunto de llaves de vaso
13 pzs.

Compositions de douilles
13 pces.

Socket set
13 pcs.

Steckschlüsselgarnitur
13-tlg.

Cromo Vanadio, cromadas,
en caja metálica

Chrome-Vanadium, chromées,
en coffret métallique

Chrome-Vanadium, chromium plated,
in metal case

Chrom-Vanadium, verchromt,
in Metallkasten

Bestell-No. Order-No.	Art.No.	Maße · Dimensions · Medidas			€
50870301583	50870-3015	318 x 119 x 49 mm	2300	1	72,50

enthaltend · containing · composition · contenido

	270 mm			MM 8, 10, 11, 13, 15, 17, 18, 19, 22, 24	
	125 mm				MM 20,8

Bestell-No. Order-No.	Art.No.	Maße · Dimensions · Medidas			€
50870311583	50870-3115	318 x 119 x 49 mm	2310	1	75,00

enthaltend · containing · composition · contenido

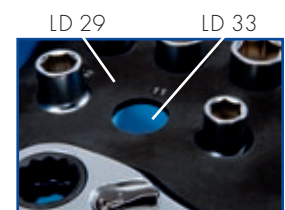

	270 mm			MM 8, 10, 11, 13, 15, 17, 18, 19, 22, 24
	125 mm			80 mm



Steckschlüsselgarnitur
21-tlg.Chrom-Vanadium, verchromt,
in Kunststoffkoffer

508101-310

Socket set
21 pcs.Chrome-Vanadium, chromium plated,
in plastic boxCompositions de douilles
21 pces.Chrome-Vanadium, chromées,
en coffret plastiqueConjunto de llaves de vaso
21 pzs.Cromo Vanadio, cromadas,
en estuche de polipropileno

Bestell-No. Order-No.	Art.No.	Maße · Dimensions · Medidas			€
50810131080	508101-310	580 x 400 x 90 mm	14000	1	311,40

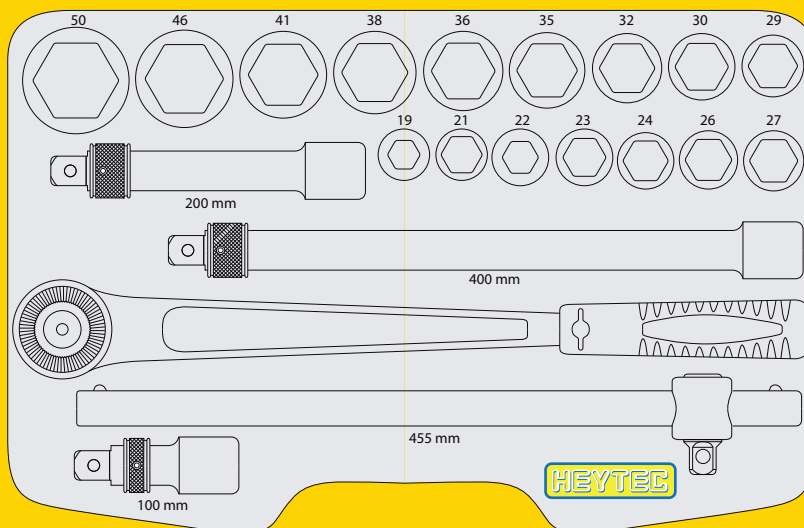

Heytec Werkstattwagen

Vertrieb: Heyco, Remscheid
Preis: um 350 Euro
Hotline: 0 21 91 / 2 05-0
Internet: www.heyco.de

Bewertung: + = -

- + Schubladenarretierung
- + innere Lackierung
- + Kippsicherheit

Note:

Anwendung: 40% 2,0 ●●●●●
Handhabung: 40% 1,5 ●●●●●
Ausstattung: 20% 1,0 ●●●●●

Oberklasse

Heimwerker Praxis Ausgabe 1/2008 **1,6**



macht mobil!

brings mobility

Werkstattwagen und Module
Workshop trolley and modules
Servante d'atelier et modules
Carros de taller y módulos



HEYTEC

simply clever!

www.heyco.de

Carro de herramientas

Servante d'atelier

Workshop trolleys

Werkstattwagen

sólida construcción en chapa metálica, rígida y resistente, 5 cajones con guías sobre rodamientos, con amplio espacio para aparatos voluminosos, máquinas etc. Cierre central con cerradura

De construction métallique robuste, haute résistance et grande capacité de charge, 5 tiroirs avec glissières à billes y compris grand casier pour outils, machines etc.. Verrouillage central avec serrure à cylindre

rigid metal construction resisting torsional forces, for high loads, 5 drawers with ball bearings and large stowage room for machines and equipment central locking with cylinder lock

In stabiler Metallkonstruktion, verwindungssteif und hochbelastbar, 5 Schubfächer mit Kugelführungen inkl. großem Staufach für Geräte, Maschinen u.ä.. Zentralverriegelung mit Zylinderschloss.

5081129



Papierkorb
Waste-paper basket
Corbeille à papier
Papelera

Papierrollenhalter
Paper roll holder
Support de rouleau de papier
Sujeción para rollo de papel

Trennblech / Satz
Divider set for drawers
Jeu de lamelles intercalaires
Juego de chapitas separadoras



Fachteiler / Satz
Slotted divider set for drawers
Jeu de casiers de rangement
Juego de divisiones

Ablageschale
Storage box
Boîte de rangement
Bandeja

Dosenhalter
Tin holder
Support pour aérosols
Sujeción de botes

Zubehör siehe gültige HEYCO Preisliste art.no. 1129-8-1 to 12
Accessories please see the actual HEYCO pricelist art no. 1129-8-1 to 12
Accessoires, voir Heyco liste de prix actuelle art. no. 1129-8-1 à 12
Accesorios, por favor, ver lista actual de precios HEYCO, artículo nr. 1129-8-1 al 12

Bestell-No. Order-No.	Art.No.	Maße · Dimensions · Medidas			€
50811290120	5081129	(L) 600 x (B) 440 x (H) 950 mm	54000	1	505,90

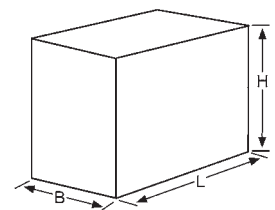

Protección para carro de taller

Protection pour Servante d'atelier

Nylon cover for workshop trolley

Abdeckhaube für Werkstattwagen

Nylon 210 D PU

nylon 210 D PU

Nylon 210 D PU

210 D PU Nylon

5081129-15



Preis und Lieferung ohne Werkstattwagen

Bestell-No. Order-No.	Art.No.	Maße · Dimensions · Medidas			€
50811291500	5081129-15	(L) 730 x (B) 500 x (H) 850 mm	345	1	13,50

Precio y suministro no incluyen el carro de taller

Prix et livraison sans servante d'atelier

price and delivery exclusive of tool trolley

Werkstattwagen
mit Modulen

90-tlg. in 5 Modulen

5081129-25

5081129

Workshop trolley
with modules

90 pcs. in 5 modules

Servante d'atelier
avec modules

90 pces. en 5 modules

Carro de herramientas
con modulos

90 pzs. en 5 módulos



M 50829-4



M 50829-13



M 50829-12





M 50829-3



M 50829-14

Details siehe Seite 37-40
 Deatils see page 37-40
 Presentoirs voir page 37-40
 Expositores, véase página 37-40

Bestell-No. Order-No.	Art.No.	Module · Modules · Módulos	 g		€
50811292500	5081129-25	M 50829-3 · M 50829-4 M 50829-12 · M 50829-13 M 50829-14	64900	1	768,00

100-tlg. in 8 Modulen

5081129-28

5081129

100 pcs. in 8 modules

100 pces. en 8 modules

100 pzs. en 8 módulos



M 50829-4



M 50829-16



M 50829-13



M 50829-12



M 50829-14



M 50829-8





M 50829-5



M 50829-15

Details siehe Seite 37-40
 Deatils see page 37-40
 Presentoirs voir page 37-40
 Expositores, véase página 37-40

Bestell-No. Order-No.	Art.No.	Module · Modules · Módulos	 g		€
50811292800	5081129-28	M 50829-4 · M 50829-5 M 50829-8 · M 50829-12 M 50829-13 · M 50829-14 M 50829-15 · M 50829-16	66910	1	925,00

Equipamiento de cajones del carro de taller heytec 5081129 con módulos

Equipement des tiroirs de la servante d'atelier Heytec 5081129 avec modules

Variable assembly alternatives with modules for workshop trolley HEYTEC 5081129

Variable Bestückung der Schubladen im Werkstattwagen HEYTEC 5081129 mit Modulen

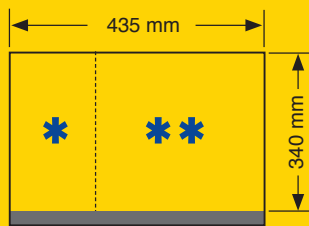
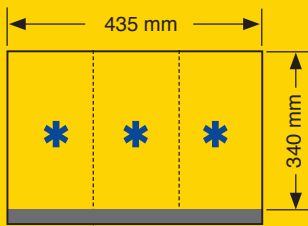

Hochwertiger 2-K Schaumstoff
High grade 2 components foam material
Garniture 2-K en mousse de haute qualité
Plástico expandido de calidad 24K

Módulos con herramientas

Modules avec outils

Tool modules

Werkzeugmodule



Modul

Juego de 17 llaves combinadas, con perfil especial SP, módulo doble

Jeu de clés mixtes, 17 pièces, avec profil de protection, module double

Combination wrench set, 17 pcs. with SP-profile, double modul

Ringmaulschlüsselsatz, 17-tlg. mit Schonprofil, Doppelmodul

M 50829-4



340 x 290 x 40 mm

Bestell-No. Order-No.	Art.No.	MM	g	Box	€
50829000480	M 50829-4	6-7-8-9-10-11-12-13-14-15-16-17-18-19-20-21-22	4400	1	61,65



Modul

Juego de 10 llaves fijas de boca abierta

Jeu de clés à fourche, 10 pcs.

Double open ended jaw wrench set, 10 pcs.

Doppelmaulschlüsselsatz, 10-tlg.

M 50829-3



340 x 145 x 40 mm

Bestell-No. Order-No.	Art.No.	MM	g	Box	€
50829000380	M 50829-3	8x9-10x11-12x13-14x15-16x17-18x19-20x22-21x23-24x27-30x32	1832	1	46,00



Modul

Juego de 7 accesorios de accionamiento.

Carraca reversible con mango ergonómico de dos componentes, alargadera de 250 mm con conexión corrediza, alargadera de 125 mm, articulación universal, vasos para bujías de 16 mm y 20,8 mm

Jeu d'accessoires, 7 pcs.

Cliquet réversible avec poignée ergonomique à 2 composantes, Rallonge 250 mm avec poignée coulissante, Rallonge 125 mm, cardan universel, Douilles pour bougies 16 mm et 20,8 mm

Set of accessories, 7 pcs.

Reversible ratchet with ergonomic 2 components handle, extension bar 250 mm with sliding Thread, extension bar 125 mm, universal joint, spark plug sockets 16 mm and 20,8 mm

Betätigungswerkzeugsatz, 7-tlg.

Hebelumschaltknarre mit ergonomischem 2-K Griff, Verlängerung 250 mm mit Gleitstück, Verlängerung 125 mm, Kardangelenk, Zündkerzeneinsätze 16 mm und 20,8 mm

M 50829-13



340 x 145 x 40 mm

Bestell-No. Order-No.	Art.No.	MM	g	Box	€
50829001383	M 50829-13	16-20,8	1670	1	62,70



Modul

20-tlg. Steckschlüsselsatz

bestehend aus 17 Steckschlüsseleinsätzen
und drei extra langen Einsätzen,
mit Schon-Profil

M 50829-12

340 x 145 x 40 mm

**Socket set, 20 pcs.**

Socket set consisting of
17 sockets and 3 extra deep
sockets, with SP-profile

Jeu de douilles 20 pcs.,

composé de 17 douilles et 3
douilles extra-longues, avec profil
de protection,

Juego de llaves de vaso, 20 pzs.,

conteniendo 17 llaves de
vaso y 3 vasos largos, con
perfil especial SP

Bestell-No. Order-No.	Art.No.	Ø mm	MM	g		€
50829001283	M 50829-12	40	10-11-12-13-14-15-16-17	1974	1	57,50
		40	18-19-20-22-24-27-30-32			
		75	13-17-19			

Modul

Steckschlüsselsatz, 36-tlg.

Hebelumschaltbar mit ergonomischem
2-K Griff, Verlängerungen 50, 100mm,
Kardangeln, Steckgriff,
Steckschlüsseleinsätze mit Schon-Profil,
Schraubendrehereinsätze für Schlitz-,
Kreuz-, Innensechskant-, und
Torxschrauben mit Stirnlochbohrung

M 50829-14

340 x 145 x 40 mm

**Socket set, 36 pcs.**

consisting of reversible ratchet with
ergonomic 2 components handle,
extension bars 50, 100 mm, universal
joint, spinner handle, sockets with SP-
profile, screwdriver sockets for plain
slot, cross slot, hexagon socket and
Torx screws

Jeu de douilles 36 pcs.,

Cliquet réversible avec poignée ergo-
nomique à 2 composants, rallonges
de 50 et 100 mm, cardan universel,
poignée d'entraînement, douilles avec
profil de protection, douilles-tournevis
pour vis à fente, en croix, six-pans
femelle et Torx

Juego de llaves de vaso, 36 pzs.

Carraca reversible con mango
ergonómico de dos componentes,
alargaderas de 50 y 100 mm,
articulación universal, mango recto,
llaves de vaso con perfil especial SP,
puntas de destornillador para tornillos
ranurados, Phillips, Allen y Torx

0,8x4
1x5,5

3, 4, 5, 6

TT15
TT20
TT25
TT30PZ 1
PZ 2

Bestell-No. Order-No.	Art.No.	Ø mm	MM	g		€
50829001483	M 50829-14	25	4-4,5-5-6-7-8-9-10-11-12-13	1025	1	68,95
		50	6-7-8-9-10-11-12-13			

Modul

**Schraubendrehersatz mit
2K-Griff, 6-tlg.**

Werkstatt, Kreuzschlitzschraubendreher
und Spannungsprüfer

M 50829-8

340 x 145 x 40 mm

**Screwdriver set 6 pcs.**

screwdrivers with 2 components
plastic handles for plain slot and
cross slot screws, voltage tester

**Jeu de tournevis avec poignée à 2
composantes, 6 pcs.,**

Tournevis d'atelier à fente et en croix
et détecteurs de tension

**Juego de destornilladores con
mango de dos componentes,
6 pzs.,**

destornilladores para tornillos
ranurados y Phillips, buscapolos

Bestell-No. Order-No.	Art.No.	Ø mm	+	g		€
50829000880	M 50829-8	4x75 · 5,5x125 · 6,5x150 mm	PH 1 · PH 2	553	1	36,60

Modul

**VDE-Schraubendrehersatz
mit 2K-Griff, 6-tlg.**

nach IEC 60900,
DIN 7437 u. DIN 7438 PZ,
mit umspritzter Klingenisolierung

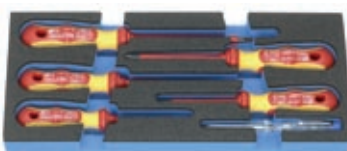
M 50829-10

340 x 145 x 40 mm



VDE-Screwdriver set, 6 pcs.
with 2 components plastic handles
complying with IEC 60900, DIN
7437 and DIN 7438 PZ, insulation
of blade and handle injection
moulded as one unit

**Jeu de tournevis VDE avec poignée
à 2 composantes, 6 pcs.**

conforme aux spécifications
IEC 60900 : DIN 7437 et DIN
7438 PZ, avec isolation de la lame
par injection

**Juego de destornilladores VDE,
6 pzs.,**

con mango de dos componentes,
homologados según normas IEC
60900, DIN 7437 y
DIN 7438 PZ,
varillas con aislamiento inyectado

Bestell-No. Order-No.	Art.No.	Ø mm	+	g		€
50829001033	M 50829-10	2,5x75 · 4x100 · 5,5x125 mm	PZ 1 · PZ 2	583	1	41,80

Modul

Juego de 3 pzs.,
tenaza poliasidora machihemb-
rada 250 mm, martillo de peña
300 g con mango de fibra de
vidrio, tenaza grip universal de 250
mm

Pince multiprise et pince-étai,
3 pces.
marteau de mécanicien 300 g
avec manche en fibres,
Pince multiprise 250 mm,
Pince-étai universelle 250 mm

Set of pliers and hammer, 3 pcs.
multigrip plier with box joint,
250 mm, universal grip plier, 250
mm engineers' hammer 300 g,
with fibreglass handle

Zangenmodul mit Schlosserhammer, 3-tlg.
Schlosserhammer 300 g mit Fiberglas-
stiel, Greifzange mit durchgestecktem
Gewerbe 250 mm, Universal-Gripzange
250 mm

M 50829-5



340 x 145 x 40 mm

Bestell-No. Order-No.	Art.No.				€
50829000500	M 50829-5		1325	1	43,90



Modul

Juego de llaves combinadas con
carraca reversible, de 13 pzs.,
con 3 adaptadores para 1/4",
3/8" y 1/2"

Jeu de clés mixtes à cliquet
réversible, 13 pces.,
y compris 3 adaptateurs pour 1/4",
3/8" et 1/2"

Set of combined ratchet wren-
ches, reversible, 13 pcs.,
including 3 adapters for 1/4",
3/8" and 1/2"

Knarrenringmaulschlüsselsatz
umschaltbar, 13-tlg.
inkl. 3 Adapter für 1/4", 3/8" und 1/2"

M 50829-2



340 x 145 x 40 mm

Bestell-No. Order-No.	Art.No.				€
50829000280	M 50829-2	8-10-12-13-14-15-16-17-19-22	1536	1	207,95



Modul

Juego de llaves combinadas con
carraca reversible, de 13 pzs.,
con adaptadores de 1/4", 3/8"
y 1/2"

Jeu de clés mixtes à cliquet,
13 pces.,
y compris 3 adaptateurs pour 1/4",
3/8" et 1/2"

Set of combined ratchet
wrenches 13 pcs.,
including 3 adapters for 1/4",
3/8" and 1/2"

Knarrenringmaulschlüsselsatz, 13-tlg.
inkl. 3 Adapter für 1/4", 3/8" und 1/2"

M 50829-9



340 x 145 x 40 mm

Bestell-No. Order-No.	Art.No.				€
50829000980	M 50829-9	8-9-10-12-13-14-15-16-17-19	1319	1	152,55



Modul

Juego de herramientas para cam-
bio de ruedas, de 4 pzs.,
con 3 llaves de vaso de impacto
con agujero para fijación, incluidos
protectores de plástico para no
dañar llantas de aluminio,
rascador de plástico para eliminar
contrapesos pegados

Jeu pour écrous de roues 4 pces.,
composé de 3 douilles impact avec
trou pour bille et manchon plastique
de protection des jantes en
aluminium, Racloir en plastique pour
enlever les masses d'équilibrage
adhésives

Set of 4 tools for wheel changing,
consisting of 3 impact sockets with
ball retaining groove, including
plastic sleeves for protecting alloy
rims, plastic scraper for removing
glued balancing weights

Radwechselsatz 4-tlg.
bestehend aus 3 Impact-Einsätzen mit
Kugelfangbohrung, inkl. Kunststoffhülsen
zum Schutz von Alufelgen,
Kunststoffschaaber zum Entfernen von
Klebegewichten

M 50829-11



340 x 145 x 40 mm

Bestell-No. Order-No.	Art.No.				€	
50829001100	M 50829-11	17-19-21	85	842	1	57,50

Modul

Zangensatz, 3-tlg.
Kombinationszange,
gerade Flachrundzange,
Seitenschneider schwedische Form,
mit Kunststoffhandschutz

M 50829-15



340 x 145 x 40 mm



Set of Pliers, 3 pcs.
Combination Plier, Snipe Nose
Plier, Diagonal Cutting Nipper, with
plastic handle



Bestell-No. Order-No.	Art.No.
50829001542	M 50829-15

Jeu de pinces, 3 pcs.
Pince universelle Pince à becs
demi-ronds, droite, Pince coupante
diagonale modèle suédois,
avec gaine plastique



Cl	mm
	185
	200
	165

Conjunto de 3 alicates:
alicate universal alicate de radio
recto cortalambres modelo sueco,
con fundas de plástico



		€
715	1	59,00

Modul

Doppelringschlüsselsatz, 8-tlg.
tief gekröpft, mit Schonprofil

M 50829-16

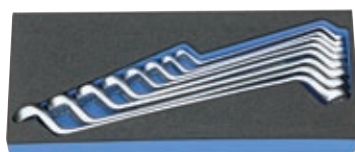

340 x 145 x 40 mm



**Double Ended Ring Wrench Set,
8 pcs.**
deep offset, profile saver

Clés polygonales coudées, 8 pcs.
avec profil de protection des têtes
de vis

**Llaves boca estrella acodadas,
8 pzs.,** codo profundo, dentado
con perfil SP



Bestell-No. Order-No.	Art.No.
50829001680	M 50829-16



Cl	MM
	6x7-8x9-10x11-12x13
	14x15-16x17-18x19-20x22

		€
1250	1	37,50

Modul

**Schraubendrehereinsatz Sortiment,
24-tlg.**
bestehend aus 12 Stk. Sechskant- und
12 Stk. TORX®-Schraubendrehereinsätzen

M 50829-17



340 x 145 x 40 mm



**Set with Screwdriver Sockets,
24 pcs.**
cons. of 12 pcs. hexagon- and
12 pcs. TORX®-Screwdriver Sockets

**Composition de douilles-tournevis
24 pcs.**
dont 12 pcs hexagonales
et 12 pcs TORX®

**Conjunto de llaves de vaso con
destornillador, 24 pzs.,**
compuesto de 12 pzs. de punta
Allen y 12 de punta TORX®

Bestell-No. Order-No.	Art.No.		Cl	mm		Cl	mm			€
50829001783	M 50829-17	5	62	T 25	62	2525	1			87,50
		6	62	T 27	62					
		6	100	T 30	62					
		7	62	T 30	100					
		8	62	T 40	62					
		8	100	T 40	100					
		10	62	T 45	62					
		10	100	T 50	62					
		12	62	T 50	100					
		12	100	T 55	62					
		14	62	T 60	62					
		17	62	T 60	100					

Maleta de herramientas
bosque, campo, jardín

120 pzs. en 3 módulos

Coffret d'outillage pour
la chasse, la nature et les loisirs

120 pces. en 3 modules

Tool Box
Forestry - Nature - Leisure

120 pcs. in 3 modules

Werkzeugkoffer
Jagd, Natur, Freizeit

120-tlg. in 3 Modulen

50868



FORESTMAN

Professional Outdoor Toolset

Jagd, Natur, Freizeit
Forestry, Nature, Leisure

hochwertige Aluminium-Box

- verstärkt durch profilierte Sieben
- witterungs- und temperaturbeständig
- selbsteinklappende Sicherheitshandgriff
- umlaufende Gummidichtung im Kantenprofil als Schutz vor Staub und Spritzwasser

High-grade Aluminium-Box

- profiled beads for reinforcement
- resistant to exposure and temperatures
- self-folding safety handle
- surrounding rubber sealing in profiled edge for protection against dust and spray

Coffret en aluminium de haute résistance

- cornières de renforcement
- résiste aux intempéries et températures
- poignée de sécurité à rabat automatique
- caoutchouc d'étanchéité totale pour protéger contre les poussières et projections

Maleta de aluminio de gran calidad,

- con perfil protector en los cantos
- Resistente a la intemperie
- Asa de seguridad, auto-plegable
- Junta de goma en el canto que sella el contenido contra polvo y humedad



50868-1

- 1 Paar Arbeitshandschuhe
- 1 Autolichtprüfer 6 - 24 V
- 1 Sicherheits-Rettungsmesser, Länge 200 mm
- 1 LED-Solar-Stablampe, Länge 180 mm
- 1 Profi-Bandmass, 5 m
- 1 Puk-Handsäge mit 2 Sägeblättern
- 1 Rolle Isolierband, Textilgewebe
- 1 Gartenschere
- 20-tgl. Nagelsortiment
4,6 x 130 mm/3,1 x 65 mm
- 1 leere Kunststoffbox (für Kleinteile)
- 1 Spannungsprüfer 250 V
- 1 Latthammer, Vollstahl 600 gr.
- 1 Sicherheits-Klappsäge
- 1 Pollerschlüssel, 3-kt, M 10 x M 12, DIN 3222/3223
- 1 Stirnleuchte mit Batterien



50868-2

- 1 Zündkerzenschlüssel 13 x 19 für fast alle Motorsägen und -geräte
- 1 Handbeil 600 gr.
- 1 Rohr- und Wasserpumpenzange 240 mm
- 1 Steinmeißel 300 x 18 mm
- 1 Monier- und Rabitzzange 220 mm, isoliert
- 7-tlg. Winkelschraubendreher-Satz, 6-kt, 1,5 - 6 mm
- 7-tlg. Winkelschraubendreher-Satz, TORX, T10 - T40
- 1 Fäustel, Fiberglasstiel, 1.000 gr.
- 1 Einmaulschlüssel, verstellbar 0 - 25 mm



FORESTMAN

- 1 Pair of Working Gloves
- 1 Car Light tester 6 - 24 V
- 1 Safety-Rescue Knife, 200 mm long
- 1 LED Solar Torch, 180 mm long
- 1 Professional Measuring Tape, 5 m
- 1 Universal Mini Hacksaw Frame with 2 blades
- 1 Roll of Isolating Tape, textile fabric
- 1 Pair of Garden-Shears
- 1 Assortment of 20 pcs. of Nails
4,6 x 130 mm/3,1 x 65 mm
- 1 Empty Plastic Box for bits and pieces
- 1 Voltage Tester 250 V
- 1 All Steel Carpenters Hammer, 600 gr.
- 1 Foldable Safety Saw
- 1 Triangular Wrench for bollards, M 10 x M 12, DIN
- 1 Headlamp with batteries
- 1 paire de gants de travail.
- 1 contrôleur de tension 6 - 24 V.
- 1 couteau de survie de sécurité, L 200 mm.
- 1 lampe de poche solaire à LED, L 180 mm.
- 1 mètre-ruban professionnel, 5 M.
- 1 mini-scie à découper et 2 lames.
- 1 rouleau de bande isolante en toile textile.
- 1 sécateur de jardin.
- 1 Assortiment de clous, 20 pces
(4,6x130 mm/3,1x165v mm).
- 1 boîte plastique vide (pour petites pièces).
- 1 tournevis détecteur de tension 250 V.
- 1 marteau de charpentier 600 gr.
- 1 scie de sécurité repliable.
- 1 clé en tube triangulaire, M 10 x M 12, DIN 3222/3223.
- 1 lampe à tête avec piles.

- 1 par de guantes de trabajo
- 1 buscapolos 6 a 24 V
- 1 navaja de emergencia, largura 200 mm
- 1 linterna LED solar, largo 180 mm
- 1 flexómetro , 5m
- 1 minisiera con 2 hojas
- 1 rollo de cinta aislante
- 1 tijera de podar
- 1 Surtido de 20 clavos 4,6 x 130/3,1 x 65 mm
- 1 caja de plástico vacía, para piecerío
- 1 buscapolos 250 V
- 1 martillo de carpintero 600 grs. enteramente de acero
- 1 sierra plegable, de seguridad
- 1 llave perfil triangular, M10 x M12, DIN 3222/3229
- 1 linterna de cabeza con pilas



- 1 Spark Plug Wrench 13 x 19 for nearly all motor saws and -tools
- 1 Hatchet 600 g
- 1 Pair of Multigrip Pliers; 240 mm
- 1 Stone Chisel, 300 x 18 mm
- 1 Pair of Tower Pincers
- 1 Set of 7 pcs. of Hexagonal Head Wrenches, 1,5 - 6 mm
- 1 Set of 7 pcs. of "I"-Shaped Torx Wrenches, T10 - T40
- 1 Club Hammer with Fibreglass Handle, 1000 gr.
- 1 Adjustable Wrench, opening up to 25 mm

- 1 Clé de bougie, presque toutes les outils à moteur thermique.
- 1 hachette 600 gr..
- 1 pince multiprise 240 mm.
- 1 burin à pierre 300 x 18 mm.
- 1 tenaille russe.
- Jeu de clés mâles coudées 6-pans, 7 pces, 1,5 - 6 mm.
- Jeu de clés mâles coudées TORX, 7 pces, T10 - T40.
- 1 masse, mache en fibre, 1000 gr.
- 1 Clé à molette, réglable 0 - 25 mm.

- 1 llave de bujía 13 x 19 mm, para practicamente todo tipo de sierras y aparatos de motor
- 1 hacha 600 gramos
- 1 tenaza poliasidora 240 mm
- 1 cortafrio 300 x 18 mm
- 1 tenaza rusa, 220 mm, mango plastificado
- 1 Juego de 7 llaves Allen, 1,5 a 6 mm
- 1 Juego de 7 llaves TORX, T10 a T40
- 1 maceta 1.000 grs., mango de fibra de vidrio
- 1 Llave ajustable 0 - 25mm



FORESTMAN

1 desenchufador
 1 Juego de 22 llaves de vaso 1/4",
 MM 5 – 13
 1 Conjunto de destornillador eléctrico,
 de 32 piezas
 1 Surtido de 20 tiras para atar cables
 203 x 4,6 mm
 1 pala plegable, 3 posiciones en ángulo

Conjuntode 1/4"

(art.-no. 50829-3017 página 25)
 Carraca con bloqueo de ángulo en
 5 posiciones
 Llaves de vaso de MM 5 – 13
 Soporte de cambio rápido, imantado
 Portadestornillador, alargadera
 Puntas de destornillador, para tornillos
 con ranura, Phillips y TORX

Conjunto de destornillador eléctrico, de 32

piezas, batería de 4,5 V, 300 rpm,
 par 6,21 Nm,
 giro a derecha e izquierda, juego de
 16 puntas, con 2 soportes imantados,
 Juego de 7 brocas con portabrocas
 cargador de batería 3/5 h
 ideal para trabajos ligeros de
 artornillado y/o taladrado

1 pince à décoffrer
 1 Composition de douilles 1/4",
 MM 5 – 13, 22 pcs
 1 Composition de visseuse sur batterie,
 32 pcs
 1 Jeu de 20 attache-câbles
 203 x 4,6 mm
 1 pelle pliable à 3 positions

Composition de douilles 1/4"

(art.-no. 50829-3017 page 25)
 cliquet angulaire blocable sur 5 positions
 douilles MM 5 – 13 adaptateur magné-
 tique à changement rapide poignée
 d'entraînement,
 rallonge douilles-tournevis plat, en
 croix et TORX

Composition de 32 pcs, visseuse sur batterie.

Visseuse sur batterie de 4,5 V, 300 t/min,
 couple 6,21 Nm, marche av.+ ar.
 Jeu d'embouts 16 pcs +
 2 adaptateurs magnétiques.
 Jeu de forets 7 pcs 1 adaptateur forets.
 Chargeur de batteries 3/5 h.
 Idéale pour visser et petits travaux
 de perçage.

1 Goose Neck Ripping Bar
 1 Socket Set of 22 pcs.,
 1/4" Sq. Drive, MM 5 – 13
 1 Set of Accu-Driver and Accessories,
 32 pcs.
 1 Set of 20 pcs. of Cable Ties
 203 x 4,6 mm
 1 Foldable Spade, adjustable for
 3 working positions

Socket Set, square drive, 1/4"

(art.-no. 50829-3017 page 25)
 angled ratchet, lockable in 5 positions
 sockets MM 5 – 13
 Magnetic quick changing adapter
 Spinner handle, extension
 Screwdriver sockets for plain slot
 screws, cross slot screws, TORX socket
 screws

Set of Accu-Driver, 32 pcs.

4,5 V Accu-Driver, 300 U/min
 Torque 6,21 Nm, right and left
 movement
 Set of Bits 16 pcs. +
 2 magnetic Bitholders
 set of Drills, 7 pcs. + 1 drill holder
 3/5h battery charger
 ideal for screw- and boring
 operation

50868-3

1 Nagelisen
 1 Steckschlüsselgarnitur 1/4", 22-tlg.
 MM 5 – 13
 1 Akkuschauber-Satz, 32-tlg.
 1 Kabelbinder-Satz 203 x 4,6 mm, 20-tlg.
 1 Klappspaten, 3-fach verstellbar

Steckschlüsselgarnitur 1/4" 22-tlg.

(Art.-No. 50829-3017 Seite 25)
 arretierbare Winkelnarre
 Steckschlüssel MM 5 – 13
 magnetischer Schnellwechseladapter
 Steckgriff, Verlängerung
 Schraubendrehereinsätze Schlitz,
 Kreuzschlitz, TORX

32-tlg. Akkuschauberset

4,5 V Akku-Schrauber, 300 U/min.,
 Drehmoment 6,21 Nm, R+L Lauf,
 16-tlg. Bitsatz + 2 Magnet-Bithalter
 7-tlg. Bohrersatz + 1 Bohrer-Halter
 3/5h Ladegerät

Ideal für Schraub- und leichte
 Bohrarbeiten

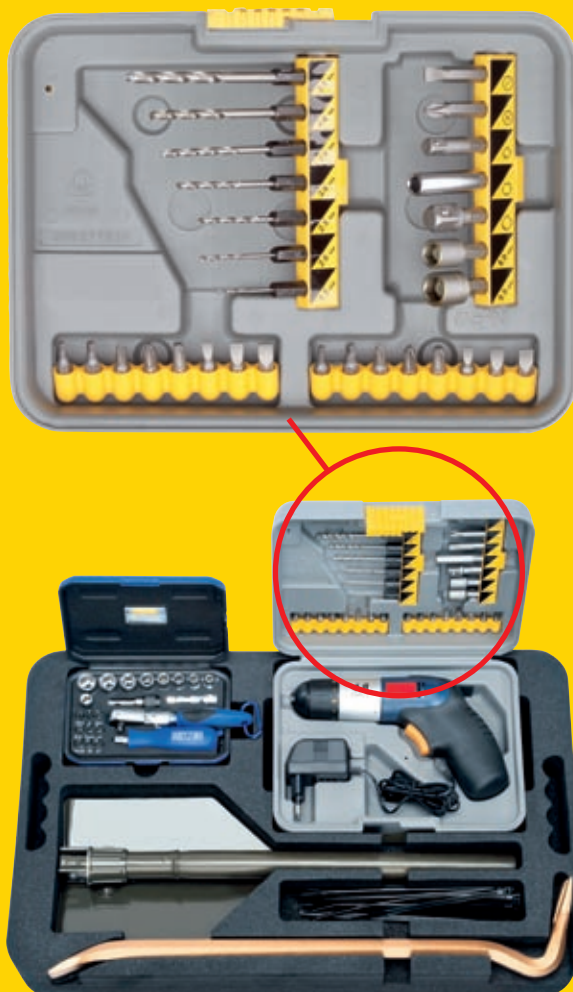

Bestell-No. Order-No.	Art.No.	Maße · Dimensions · Medidas			€
50868000000	50868	550 x 360 x 240 mm	1,5100	1	590,00

Montage-Werkzeugkasten

Tool box, cantilever type

Boîte à outils

Caja de herramientas

5-tlg. Stahlblech,
in Hammerschlagblau

5 trays, sheet steel
hammertone blue

5 compartiments, en tôle d'acier
couleur bleu martelé

5 compartimentos, en chapa de
acero, pintada en azul

98076-08

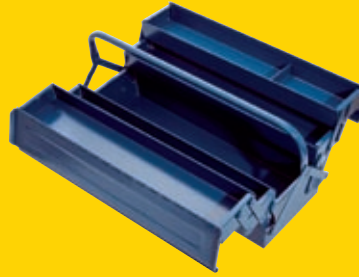

Bestell-No. Order-No.	Art.No.	Maße · Dimensions · Medidas			€
98076080020	98076-08	530 x 200 x 200 mm	3250	1	36,60

Montage-Werkzeugkasten
mit Modulen

Tool box, cantilever type
with modules

Boîte à outils
avec modules

Caja de herramientas
con módulos

5 Module, 96-tlg.

5 Modules, 96 pcs.

5 Modules, 96 pces.

5 Módulos, 96 pzs.

508076-945

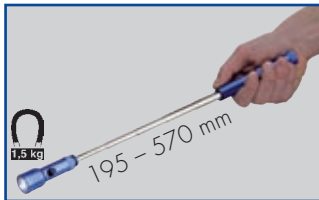

Bestell-No. Order-No.	Art.No.	Module · Modules · Módulos			€
50807694500	508076-945	M 50829-30 · M 50829-31 M 50829-32 · M 50829-33 M 50829-34	14430	1	345,00

enthaltend · containing · composition · contenido →

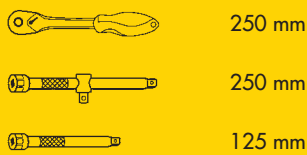

250 mm
250 mm
125 mm

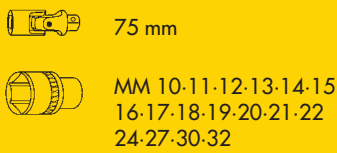

75 mm
MM 10-11-12-13-14-15
16-17-18-19-20-21-22
24-27-30-32

M 50829-30

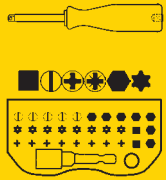
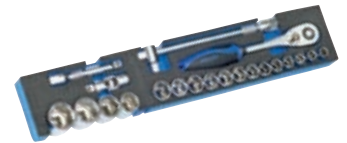

150 mm
50833-2
(siehe Seite 12
see page 12
voir page 12
véase página 12)

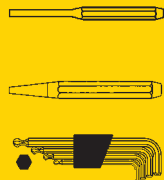

Ø 3 x 150 mm · Ø 4 x 150 mm
Ø 5 x 150 mm · Ø 6 x 150 mm
Ø 3 x 150 mm · Ø 4 x 150 mm
MM 1,5-2-2,5-3
4-5-6-8-10

M 50829-31

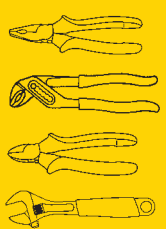
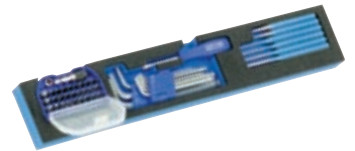

180 mm
240 mm
180 mm
255 mm

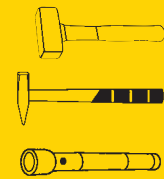

1000 g
300 g
195 - 570 mm

M 50829-32

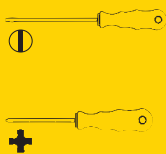

4,0 x 75 mm
5,5 x 125 mm
6,5 x 150 mm
PH 1, PH 2



3 x 65 mm

M 50829-33

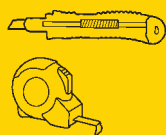
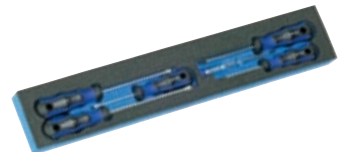

170 mm
5 m



MM 8 · 10 · 12 · 13 · 14 · 15
16 · 17 · 19 · 22 · 24

M 50829-34



Bestell-No. Order-No.	Art.No.	Module · Modules · Módulos			€
50829003083	M 50829-30	528 x 98 x 35 mm	2954	1	83,00
50829003100	M 50829-31	528 x 98 x 35 mm	1063	1	52,00
50829003200	M 50829-32	528 x 195 x 35 mm	3040	1	98,00
50829003380	M 50829-33	528 x 98 x 35 mm	483	1	39,00
50829003480	M 50829-34	528 x 98 x 35 mm	1888	1	52,00

M 50829-30 - 34

Módulo intercambiable
para caja de herramientas

Module alternatif pour
boîte à outils pour monteurs

Exchange modul
for tool box set

Austauschmodul
für Montage-Werkzeugkasten

M 50829-35

Bestell-No. Order-No.	Art.No.	enthaltend · containing composition · contenido			€
50829003580	M 50829-35	 MM 6x7 · 8x9 · 10x11 · 12x13 14x15 · 16x17 · 18x19 · 20x22 MM 6x7 · 8x9 · 10x11 · 12x13 14x15 · 16x17 · 18x19 · 20x22	1960	1	49,00

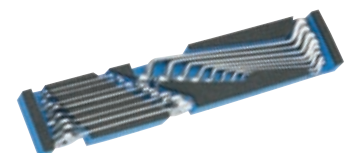

Drehmomentschlüssel
mit HebelumschaltknarreChrom-Vanadium
in Kunststoffbox50880
50882
50885Torque wrenches with
reversible ratchetChrome-Vanadium
in plastic boxClé dynamométrique avec
 cliquet réversibleChrome-Vanadium
en coffret plastiqueLlaves dinamométrica
con carraca reversibleCromo Vanadio
en estuche de polipropileno1/4"
3/8"
1/2"

Hebelumschaltknarre
mit Auswerferstift zum Schnelllösen
der Steckverbindung

Lever type reversible ratchet
with quick release ejector button

Cliquet réversible
tige d'éjection pour libérer
rapidement l'outil du cliquet

Carraca reversible
con expulsor para separación
instantánea de vasos y accesorios

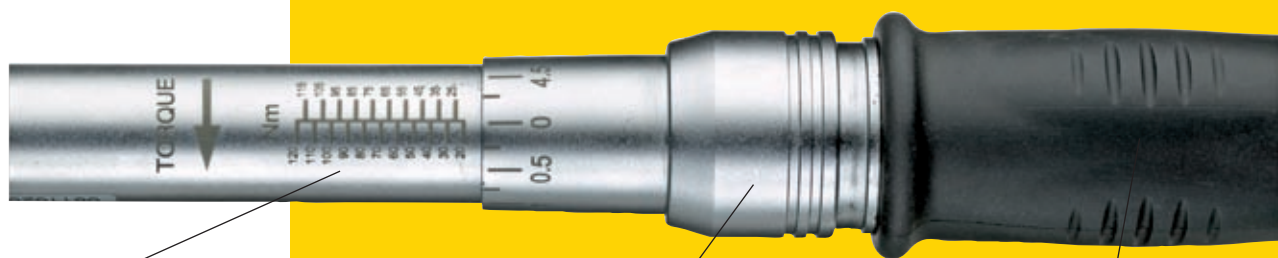

gut einstellbare, deutlich lesbare Skala
clearly visible scale
échelle de graduation facilement ajustable
et très lisible
escala nitidamente legible, de fácil ajuste

Verriegelung des eingestellten Drehmomentwertes
locking of set torque
verrouillage du couple sélectionné
bloqueo del par de apriete seleccionado

rutschfester Drehgriff für sichere Handhabung
und zum Einstellen des Drehmomentwertes
Nonskid turning handle for safe handling and
precise adjustment of torque value
Poignée tournante anti-glisse pour une
prise en main sûre et pour régler le couple
Empuñadura giratoria para un manejo
seguro y para ajustar el par de apriete

Bestell-No. Order-No.	Art.No.	■	Nm	CLD mm	g		€
50880000080	50880	1/4"	4 - 20	300-320	865	1	84,90
50882000080	50882	3/8"	20 - 120	405-435	1665	1	104,90
50885000080	50885	1/2"	40 - 200	485-510	2020	1	109,50

Conjunto de herramientas de calidad, para uso doméstico, en la oficina y de viaje. Presentadas en una bolsa de plástico práctica y de reducidas dimensiones, con cierre. Muy recomendable para regalo publicitario.

Composition d'outillage de qualité pour l'entretien de la maison, du bureau à domicile ou en voyage. Rangés en trousse similibuir pratique et compacte, avec fermoir. Optimal aussi dans le domaine des cadeaux d'affaires.

Assortment of most commonly used quality tools for office and household. For at home and on the road. Practical and suitably presented in tool wallet of imitation leather and with inter-locking clasp fastener. Particularly suitable for marketing through advertising and publicity companies.

Zusammenstellung der gebräuchlichsten Qualitätswerkzeuge für Haushalt und Büro; für zuhause oder unterwegs. Praktisch und platzsparend, verpackt in ansprechender Kunstledertasche mit Verschluss. Optimal auch in der Werbebranche einsetzbar.

Herramientas de calidad
7 pzs.

Trousse d'outillage à usage
domestique, 7 pces.

Household tool wallet
7 pcs.

Haushalts-Werkzeuggtasche
7-tlg.

50890-10



Bestell-No. Order-No.	Art.No.	Maße · Dimensions · Medidas			€
50890100100	50890-10	300 x 220 x 60 mm	1350	1	43,20

enthaltend · containing · composition · contenido

	240 mm		2 m		220-250 Volt
	200 g		125 mm		6,5 mm x PH 2
	160 mm				

Herramientas de calidad
14 pzs.

Trousse d'outillage à usage
domestique, 14 pces

Household tool wallet
14 pcs.

Haushalts-Werkzeuggtasche
14-tlg.

50890-20



Bestell-No. Order-No.	Art.No.	Maße · Dimensions · Medidas			€
50890200200	50890-20	670 x 340 mm	1350	1	78,40

enthaltend · containing · composition · contenido

	240 mm		2 m		220-250 Volt
	225 mm		125 mm		PH 1, PH 2
	300 g		190 mm		4,0 x 75
	160 mm				5,5 x 125
	205 mm				6,5 x 150

Impact-Steckschlüssel
SW 17, 19 mm

Chrom-Molybdän-Stahl,
mit Kunststoffhülse und Kunststoffeinsatz
zum Schutz von Alufelgen.
Mit Kugelfangrille und Bohrung,
gefederte Magnethalterung für
Hand- und Schlagschrauberbetrieb.

5086300-B
5086300-19-B

NEW

- Magnetische Aufnahme
- sicherer Halt für die gelöste Mutter
- federnder Einsatz
- maximaler Formschluss durch Längenanpassung

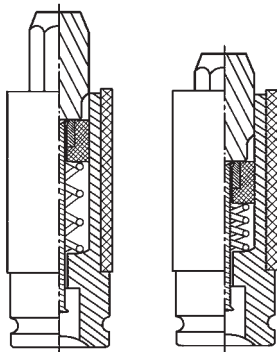
Impact sockets
17, 19 mm

chrome-molybdenum steel
for protection of alloy wheels,
with ball retaining groove and bore
hole for manual operation or impact
and power driven tools

Douilles impact
SW 17, 19 mm

acier au Chrome-Molybdène,
avec gaine plastique de protection
des jantes en aluminium, Avec
élément de retenue de la bille, pour
utilisation à main et à choc

Llaves de vaso de impacto
Boca de 17, 19 mm

acero al cromo molibdeno,
con protectores de plástico para
no dañar llantas de aluminio,
con ranura y agujero para su
fijación, para apriete manual y a
máquina

○ **NEUHEIT** ○

Top Produkt
exklusiv aus dem Hause HEYCO

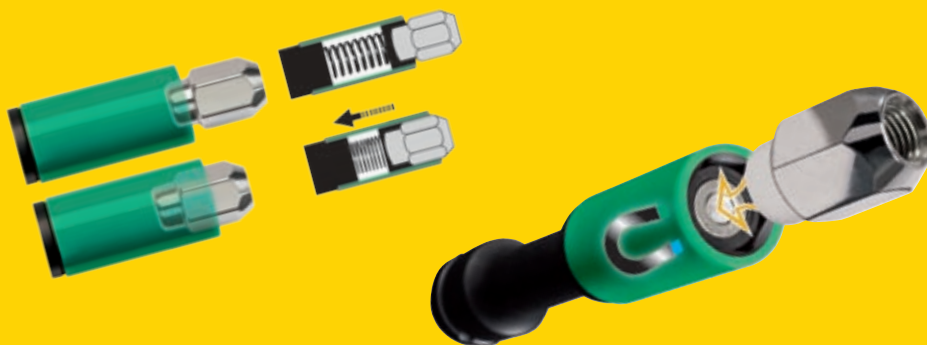

5086300-B

Bestell-No. Order-No.	Art.No.	ØMM	CL mm	g	g	€
50863001730	5086300-B	17	85	216	1	11,80
50863001930	5086300-B	19	85	227	1	11,80



5086310-B

Bestell-No. Order-No.	Art.No.	ØMM	CL mm	g	g	€
50863191730	5086300-19-B	17	150	375	1	29,00
50863191930	5086300-19-B	19	150	400	1	29,00

Llaves de vaso de impacto
Boca de 17, 19 y 21 mm

acero al cromo molibdeno, con protectores de plástico para no dañar llantas de aluminio, con ranura y agujero para su fijación, para apriete manual y a máquina

Douilles impact
SW 17-19-21 mm

acier au Chrome-Molybdène, avec gaine plastique de protection des jantes en aluminium, Avec élément de retenue de la bille, pour utilisation à main et à choc

Impact sockets
17, 19, 21 mm

chrome-molybdenum steel for protection of alloy wheels, with ball retaining groove and bore hole for manual operation or impact and power driven tools

Impact-Steckschlüssel
SW 17-19-21mm

Chrom-Molybdän-Stahl, mit Kunststoffhülse und Kunststoffeinsatz zum Schutz von Alufelgen. Mit Kugelfangrinne und Bohrung, für Hand- und Schlagschrauberbetrieb.



5086300

Bestell-No. Order-No.	Art.No.	MM	mm	g		€
50863001760	5086300	17	85	216	1	7,85
50863001960	5086300	19	85	227	1	7,85
50863002160	5086300	21	85	255	1	7,85



5086300-19

Bestell-No. Order-No.	Art.No.	MM	mm	g		€
50863191760	5086300-19	17	150	375	1	16,95
50863191960	5086300-19	19	150	400	1	16,95
50863192160	5086300-19	21	150	440	1	16,95



5086300 - 5086300-19

Llaves de vaso de impacto

De 3 piezas, con protectores de plástico, en estuche

Composition de
douilles impact

3 pièces avec gaine plastique en boîte

Impact sockets sets

3 pcs. in box, with plastic sleeves and plastic inserts

Impact-Steckschlüsselsatz

3-tlg. mit Kunststoffhülse in Box

Bestell-No. Order-No.	Art.No.	MM	mm	g		€
50863000300	5086300-3	17-19-21	85	820	1	26,00

5086300-3



De 6 piezas, con protectores de plástico, en estuche, extra largas para llantas con asientos de tornillo profundos, bocas hexagonales de 17, 19 y 21 mm, con 3 protectores de plástico de recambio

6 pièces avec gaine plastique en boîte, extra-longues pour jantes à base creuse SWV 17-19-21 mm et 3 gaines plastique de rechange

Set of 6 pcs. in box, including 3 spare sleeves, extra long for full drop center rims, 17, 19, 21 mm

6-tlg. mit Kunststoffhülse in Box Extra lang für Tiefbeifelgen SW 17-19-21 mm + 3 Ersatz Kunststoffschonhülsen

Bestell-No. Order-No.	Art.No.	MM	mm	g		€
50863190300	5086300-19-3	17-19-21	150	1460	1	55,00



5086300-19-3

Greifzange

Mit durchgestecktem Gleitgelenk,
Chrom-Vanadium, lackiert, teilweise
geschliffen, Griffe kunststoffbeschichtet

50253



Multigrip Plier

With box joints, chrome-vanadium,
laquered, partly ground, plastic
coated handles

Pincès multiprise

Charnière entrepassée et glissière,
chrome-vanadium, laquées
partiellement meulée, branches
gainées plastique

Tenaza de abertura
multiple

Unión machihembrada, cromo
vanadio, pintada, parcialmente
pulida, mangos plastificados

Bestell-No.
Order-No.

Art.No.
50253

Ø
mm

240

g

385

1

1

€

7,45

Kombinationszange
DIN ISO 5746

Kopf geschliffen und lackiert,
Griffe mit 2-K Kunststoffhandschutz,
Schneide für mittelharten Draht

5081200

Combination Plier
DIN ISO 5746

head ground and lacquered
with 2K plastic handle
cutting edges for middlehard wire

Pince universelle
DIN ISO 5746

Chromées et laquées branches
gainées plastique à 2 composantes,
pour fil de dureté moyenne

Alicata universal
DIN ISO 5746

Cabeza amolada y barnizada,
mangos con funda de plástico
cortante para alambre semi-duro



2,5

Bestell-No.
Order-No.

Art.No.
5081200

Ø
mm

180

g

260

1

1

€

16,90

Flachrundzange,
gerade DIN ISO 5745

Kopf geschliffen und lackiert,
Griffe mit 2-K Kunststoffhandschutz,
Schneide für mittelharten Draht

5081208

Snipe Nose Plier,
straight DIN ISO 5745

head ground and lacquered
with 2K plastic handle
cutting edges for middlehard wire

Pince à becs demi-ronds,
droits DIN ISO 5745

Chromées et laquées branches
gainées plastique à 2 composantes,
pour fil de dureté moyenne

Alicata de radio,
recto, DIN ISO 5745

Cabeza amolada y barnizada,
mangos con funda de plástico
cortante para alambre semi-duro



1,8

Bestell-No.
Order-No.

Art.No.
5081208

Ø
mm

200

g

185

1

1

€

16,90

Flachrundzange,
45° abgewinkelt DIN ISO 5745

Kopf geschliffen und lackiert,
Griffe mit 2-K Kunststoffhandschutz,
Schneide für mittelharten Draht

5081209

Snipe Nose Plier,
45° angle DIN ISO 5745

head ground and lacquered
with 2K plastic handle
cutting edges for middlehard wire

Pince à becs demi-ronds,
coudés à 45° DIN ISO 5745

Chromées et laquées branches
gainées plastique à 2 composantes,
pour fil de dureté moyenne

Alicata de radio,
curvo a 45°, DIN ISO 5745

Cabeza amolada y barnizada,
mangos con funda de plástico
cortante para alambre semi-duro



1,8

Bestell-No.
Order-No.

Art.No.
5081209

Ø
mm

200

g

185

1

1

€

17,90

Alicate cortalambre
DIN ISO 5749

Pincès coupantes diagonales
DIN ISO 5749

Diagonal Cutting Nipper,
DIN ISO 5749

Kraftseitenschneider,
DIN ISO 5749

Acero especial, Cabeza amolada y barnizada, mangos con funda de plástico 2K, cortante para alambre cuerda de piano

acier spécial, chromées et laquées branches gainées plastique à 2 composants, pour fil dur (corde à piano)

head ground and lacquered with 2K plastic handle cutting edges for piano wire

Spezialstahl, Kopf geschliffen und lackiert, Griffe mit 2-K Kunststoffhandschutz, Schneide für harten Draht (Piano Draht)



5081212



Bestell-No. Order-No.	Art.No.	CL Ø mm	g	Stück	€
50812121842	5081212	180	255	1	17,90

Alicate cortalambre modelo sueco
DIN ISO 5749

Pincès coupantes diagonales modèle suédois
DIN ISO 5749

Diagonal Cutting Nipper, swedish pattern
DIN ISO 5749

Seitenschneider, schwedische Form
DIN ISO 5749

Cabeza amolada y barnizada, mangos con funda de plástico 2K, cortante para alambre semi-duro

Chromées et laquées branches gainées plastique à 2 composants, pour fil de dureté moyenne

head ground and lacquered with 2K plastic handle cutting edges for middlehard wire

Kopf geschliffen und lackiert, Griffe mit 2-K Kunststoffhandschutz, Schneide für mittelharten Draht



5081213



Bestell-No. Order-No.	Art.No.	CL Ø mm	g	Stück	€
50812131642	5081213	160	220	1	16,90

Tenaza rusa,
DIN ISO 9242A

Tenaille
DIN ISO 9242A

Tower pincers
DIN ISO 9242A

Knief/Rabitzzange
DIN ISO 9242A

Pintada en negro mate, bocas pulidas, mangos plastificados

Laquée noir mat avec becs polis, poignées isolées

Satin black lacquered finish with polished jaws, plastic coated handles

Mattschwarz lackiert mit polierten Backen, tauchisoliert Schneide für mittelharten Draht



5081241



Bestell-No. Order-No.	Art.No.	CL Ø mm	g	Stück	€
50812412213	5081241	230	330	1	8,15

Tanazas grip

Pincès-étaux

Grip Pliers

Gripzange

palanca de desbloqueo con funda de plástico

levier de déclenchement gainé plastique

Plastic coated release lever

Lösehebel mit Kunststoffhülle

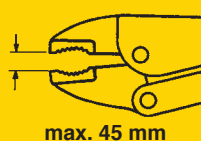

5081280



Bestell-No. Order-No.	Art.No.	CL Ø mm	g	Stück	€
50812802550	5081280	250	440	1	12,00

Hebelblechschere gerade und rechtsschneidend

geschmiedete Schneiden
aus Chrom-Vanadium, gezahnt,
Kunststoffhüllen mit Gleitschutz

5081621-1



NEW

Compound Action Snips straight, right hand cutting

forged chrom-vanadium
cutting edges, gogged, plastic
handle with slip guard

Cisailles à tôle démultipliées chantourneuse à droite

tranchant forgé en chrome-vanadium,
denté, gaines plastique avec
protection anti-glisse

Tijeras cortachapas corte recto y a derecha

cortantes forjados de acero al
cromo vanadio, dentadas, fundas
de plástico con tope protejamasos



Bestell-No. Order-No.	Art.No.	Ø mm			€
50816210132	5081621-1	260		1	25,00

Flexibler Magnetheber mit LED-Licht

verbesserte Ausführung mit
2-K-Griff

5081494



Magnetic pick-up tool with LED Light

optimised model with
2 components grip

Doigt magnétique flexible avec lampe „LED“

modèle amélioré avec poignée
à 2 composantes

Extractor magnético flexible, con lámpara LED

versión mejorada, con mango
de dos componentes



Bestell-No. Order-No.	Art.No.	Ø mm				€
50814941500	5081494	900	1.500 g	150	1	29,80

Stablampe mit LED-Licht

stufenlos ausziehbar
mit magnetischem Leuchtkopf

5081720



NEW

LED Torchlight

progressively extensible, with
lighting magnetic head

Lampe torche led

progressivement extensible,
avec tête magnétique éclairante

Linterna LED

extensible sin escalones,
con cabezal luminoso magnético



Bestell-No. Order-No.	Art.No.	Ø mm				€
50817200000	5081720	195 - 570	1.500 g	116	1	14,90

Stirnleuchte mit LED-Licht

3 Helligkeitsstufen schaltbar,
zusätzlich Blinklicht bei Volllicht,
verstellbare elastische Haltebänder

5081730



NEW

LED Headlamp

3 lighting degree,
as well winking at full intensity,
adjustable elastic support

Lampe frontale led

3 intensités d'éclairage, en plus,
lumière clignotante en position
maximale, support élastique réglable

Linterna para casco LED

3 grados de luminosidad,
además de luz intermitente en el
grado de máxima potencia, cintas
elásticas de sujeción ajustables



Bestell-No. Order-No.	Art.No.			€
50817300000	5081730	120	1	5,90

conjunto de herramientas compuesto de cortafríos, granes y punzones cilíndricos

composition de burins, bédanes et chasse-clous

chisel and pin punch set

Werkzeugsatz mit Meißel, Körner, Splint-, und Durchtreiber

en caja metálica plegable

en boîte métallique, repliable

in hinged metal box







in klappbarer Metallkassette



5081440

NEW



Bestell-No. Order-No.	Art.No.	enthaltend · containing composition · contenido	 g		€
50814400000	5081440	1  Ø 3 x 120 mm 1  Ø 5 x 150 mm 1  Ø 3 x 120 mm 1  5 x 130 mm 2  12 x 130 mm 14 x 150 mm	715	1	14,50

juego de punzones cilíndricos

jeu de Chasse-goupilles

pin punches set

Splinttreibersatz

en caja metálica plegable

en boîte métallique, repliable

in hinged metal box

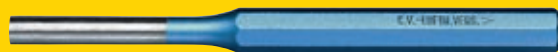

in klappbarer Metallkassette



50830

NEW



Bestell-No. Order-No.	Art.No.	enthaltend · containing composition · contenido	 g		€
50830000000	50830	6  Ø 3, 4, 5, 6, 7, 8 x 150 mm	690	1	14,50

juego de extractores multi-función, en estuche de plástico

Jeu d'extracteurs multi-fonctions en coffret plastique

Multifunction pullers in plastic box

Multifunktions-Abziehersatz in Kunststoffbox

placa base de fundición especial, brazos y husillo de acero al cromo molibdeno, función de tramas patentada sirve como extractor interior y/o exterior de 2 y 3 brazos en 8 variables. Estabilidad bajo carga como extractor de dos brazos verificado VPA - 25000 N

Support en fonte spéciale, bras extracteurs et axe en acier au chrome-molybdène, fonction crantée brevetée, utilisable en 8 variantes avec 2 ou 3 bras en prise extérieure ou intérieure stabilité sous charge 25000 N - VPA testé

Bridge made of special cast iron, puller legs and screw axis made of chrom-molybdenum, patented notching function, usable in 8 options with 2 or 3 legs for internal or external applications stability under load: 25000 N - VPA tested



Grundplatte aus Spezialguß, Abzugsarme und Spindel aus Chrom-Molybdän-Stahl, patentierte Rasterfunktion, verwendbar als 2- und 3-armige Innen-/ Außenabzieher in 8 Varianten Belastung als 2-armiger Abzieher: 25000 N - VPA getestet



5082250

NEW



Bestell-No. Order-No.	Art.No.	enthaltend · containing composition · contenido	 g		€
50822500780	5082250	1 Abzieherbrücke, 1 Gewindestift je 3 Abzieharms 130, 205 mm	2635	1	129,00

- 1 support bridge, 1 screw axis, each 3 puller legs 130, 205 mm
- 1 portique de support, 1 axe fileté, 3 bras extracteurs de chaque 130, 205 mm
- 1 puente de amarre, 1 husillo, 3 brazos de extracción de cada una de las larguras 130 y 205 mm

2-K Werkstatt-Schraubendreher

Workshop screwdrivers

Tournevis d'atelier à 2 composantes

Destornilladores de taller

2K-Schraubendreher nach DIN 5265 / 8764. Ergonomischer Softgriff. Klinge aus Chrom-Vanadium-Stahl, gehärtet und geschwärzt.

With ergonomic 2 components soft grip plastic handle, DIN 5265/8764, blades from chrome vanadium steel, hardening, with black tip

Tournevis à 2 composantes suivant DIN 5265 / 8764, Poignée souple ergonomique, Tige au Chrome Vanadium, trempée et embout bruni

Destornilladores según DIN 5265/8764 mango ergonómico de dos componentes varillas de acero al cromo vanadio, templadas y pavonadas

5084511 - 5084530



Bestell-No. Order-No.	Art.No.	⓪	+	g	📦	€
50845110180	5084511		PH 1	58	1	4,45
50845110280	5084511		PH 2	86	1	5,10
50845300480	5084530	0,8 x 4,0 x 75 mm		52	1	3,95
50845305580	5084530	1,0 x 5,5 x 125 mm		76	1	4,70
50845306580	5084530	1,2 x 6,5 x 150 mm		78	1	5,80

VDE Schraubendreher

VDE-Screwdriver

Tournevis VDE

Destornilladores VDE

2K-VDE-Schraubendreher nach IEC 60900 : 2004/VDE 006282 Teil 201 (DIN 7437 u. DIN 7438 PZ) Ergonomischer Softgriff. Klingen aus Chrom-Vanadium-Stahl, gehärtet, geschwärzt und mit umspritzter Klingenisolierung.

With ergonomic 2 components soft grip plastic handle, complying with IEC 60900 : 2004/VDE 006282 part 201 (DIN 7437 and DIN 7438 PZ) blades from chrome vanadium steel, hardened, with black tip, insulation of blade and handle injection moulded as one unit

Tournevis VDE à 2 composantes suivant IEC 60900 : 2004/VDE 006282 Section 201 (DIN 7437 et DIN 7438 PZ) Poignée souple ergonomique au Chrome vanadium, trempée, brunie et avec isolation de la tige par injection

Destornillador VDE según IEC 60900 2004/VDE 006282 apartado 201 (DIN 7437 y DIN 7438 PZ), mango ergonómico de dos componentes, varilla de acero al cromo vanadio, templada y pavonada y con aislamiento inyectado

5084512 - 5084536



Bestell-No. Order-No.	Art.No.	⓪	+	g	📦	€
50845120133	5084512 VDE		PZ 1	60	1	5,55
50845120233	5084512 VDE		PZ 2	90	1	6,60
50845367533	5084536 VDE	0,5 x 2,5 x 75 mm		54	1	4,20
50845361033	5084536 VDE	0,8 x 4,0 x 100 mm		80	1	4,95
50845361233	5084536 VDE	1,0 x 5,5 x 125 mm		82	1	5,60

Spannungsprüfer 150 - 250V vollisoliert

Voltage tester 150 - 250 V

DéTECTEURS de tension 150 - 250 V isolation totale

Buscapolos 150 - 250 V aislamiento integro

Spannungsprüfer 150-250V, vernickelte Klinge, transparenter Griff,

Blade nickel plated 0,5 x 30 mm tip, transparent handle

Contrôleurs de tension 150-250 V, poignée transparente nickelée Fente 3,0 mm

Buscapolos 150 - 250 V, varilla niquelada 0,5 x 3,0 mm, mango transparente

5081424



Bestell-No. Order-No.	Art.No.	⓪	g	📦	€
50814240050	5081424	0,75 x 3,0 x 60 mm	20	1	2,10

Llaves de vaso

Douilles

Nut Spinner

Steckschlüssel

con mango transversal con agujero, para tuercas y tornillos de cabeza exagonal, acero al cromo vanadio

avec poignées en T et trou de suspension pour vis hexagonales ext. acier au Chrome Vanadium

with T-handle and hang-up hole for hexagon socket screws Chrome-Vanadium

mit Quergriff und Aufhängebohrung, für Aussensechskantschrauben, Chrom-Vanadium

5080542

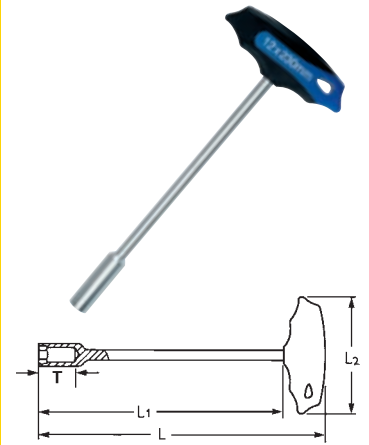

Bestell-No. Order-No.	MM	mm	L1 mm	L2 mm	T mm	g		€
50805425580	5,5	260	230	95	21,0	104	5	4,10
50805420680	6	260	230	95	21,0	106	5	4,10
50805420780	7	260	230	95	21,0	107	5	4,40
50805420880	8	270	230	115	26,0	236	5	4,60
50805420980	9	270	230	115	26,0	240	5	4,80
50805421080	10	270	230	115	26,0	242	5	4,80
50805421180	11	270	230	115	26,0	248	5	5,10
50805421280	12	270	230	115	26,0	252	5	5,10
50805421380	13	270	230	115	26,0	262	5	5,30

Juego de llaves de vaso con mango, 9 pzs.

Jeux de douilles 9 pcs.

Nut Spinner Set 9 pcs.

Steckschlüsselsatz 9-tlg.

en bolsa enrollable de poliestireno, con cintas de cierre y ojal para colgar

trousse en polyester avec lanière textile et oeillet de suspension

polyester wallet with textile strap and suspension eyelet

in Polyesterrolltasche, mit Textilbinde-schleifen und Aufhängeösen

R 5080542-9

NEW



Bestell-No. Order-No.	Art.No.	enthaltend · containing composition · contenido	g		€
50805429080	R 5080542-9	MM 5,5, 6, 7, 8, 9, 10, 11, 12, 13	2635	1	58,00

Destornilladores exagonales

Tournevis hexagonal

Hexagonal Head Wrench

Sechskant-Schraubendreher

con mango transversal con agujero, para tornillos y tuercas de cabeza exagonal, acero al cromo vanadio

avec poignées en T et trou de suspension pour vis hexagonales ext. acier au Chrome Vanadium

with T-handle and hang-up hole for hexagon socket screws Chrome-Vanadium

mit Quergriff und Aufhängebohrung, für Innensechskantschrauben Chrom-Vanadium

5081338

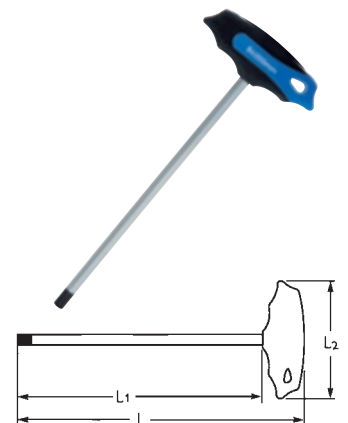

Bestell-No. Order-No.	MM	mm	L1 mm	L2 mm	g		€
50813380280	2	130	100	75	19	5	2,30
50813382580	2,5	130	100	75	21	5	2,40
50813380380	3	130	100	75	23	5	2,50
50813380480	4	180	150	75	35	5	2,70
50813380580	5	180	150	95	65	5	2,80
50813380680	6	185	150	95	79	5	3,30
50813380880	8	230	200	95	135	5	3,40
50813381080	10	240	200	115	225	5	4,00

Sechskant-Schraubendrehersatz

im Metallhalter 170 x 120 x 245 mm,
8-tlg., mit Aufhängebohrungen,
Chrom-Vanadium

H 5081338-8



Set of Hexagonal Head Wrenches

in metal holder 170 x 120 x 245 mm
8 pcs., with hang-up hole
Chrome-Vanadium

Jeu de tournevis hexagonaux

avec support en métal
170 x 120 x 245 mm
8 pces., avec trou de suspension
acier au Chrome Vanadium

Juego de destornilladores exagonales

en soporte metálico
170 x 120 x 245 mm,
con agujeros para colgar,
de 8 pzs., acero al cromo
vanadio

Bestell-No. Order-No.	Art.No.	MM	g		€
50813380080	H 5081338-8	2 · 2,5 · 3 · 4 · 5 · 6 · 8 · 10	920	1	32,90

Winkelschraubendrehersatz

im Handklapphalter,
kunststoffbeschichtet,
für Innensechskantschrauben
Spezial Stahl

H 5081340-7



Set of Hexagonal Head Wrenches

in metal holder, plastic coated
for hexagon socket screws
special steel

Jeu de clés mâles coudées

sur monture, revêtement plastique,
pour vis à pans creux
acier spécial

Juego de llaves Allen

en soporte plegable, plastificadas,
para tornillos Allen interiores
acero especial

Lieferung in Blisterverpackung
supplied in blister packing



Livré sous blister
Suministro en envase blisterizado

Bestell-No. Order-No.	Art.No.	MM	g		€
50813406280	5081340-7	1,5 · 2 · 2,5 · 3 · 4 · 5 · 6	134	5	5,75

Kugelpopf-
Winkelschraubendrehersatz

9-tlg., im Kunststoffhalter,
für schwer zugängliche
Innensechskantschrauben
Spezial Stahl

HP 5081343-9

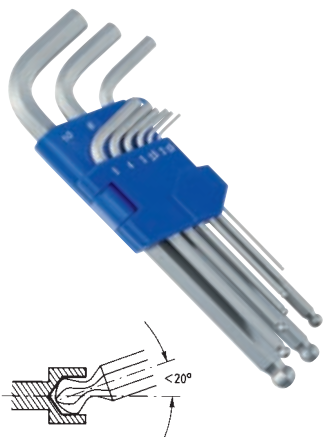

Set of Ball Head Hexagonal Wrenches

9 pcs., in plastic holder
for hexagon socket screws in
confined or hard to reach areas
special steel

Jeu de clés mâles coudées
à tête sphérique

9 pces., sur monture plastique,
pour vis à pans creux avec accès
difficile acier spécial

Juego de llaves Allen con
cabeza esférica

de 9 pzs., en soporte de plástico,
para tornillos Allen interiores de
difícil acceso, acero especial



Lieferung in Blisterverpackung
supplied in blister packing
Livré sous blister
Suministro en envase blisterizado

Bestell-No. Order-No.	Art.No.	MM	g		€
50813438280	HP 5081343-9	1,5 · 2 · 2,5 · 3 · 4 · 5 · 6 · 8 · 10	353	5	8,75

Destornilladores TORX®

Tournevis TORX®

TORX®-Screwdrivers

TORX®-Schraubendreher

con mango transversal con agujero para colgar, para tornillos TORX interiores, acero al cromo vanadio

avec poignées en T et trou de suspension pour vis TORX intérieures acier au Chrome Vanadium

with T-handle and hang-up hole for TORX socket screws Chrome-Vanadium

mit Quergriff und Aufhängebohrung, für Innen-TORX-Schrauben, Chrom-Vanadium

5081347

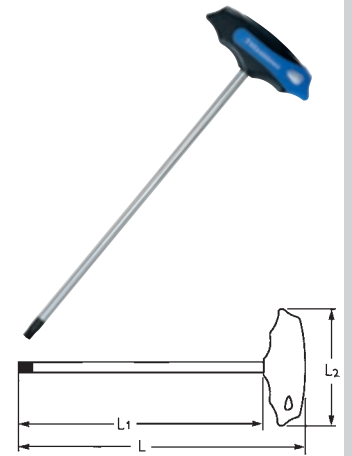

Bestell-No. Order-No.	★	★ mm	Ø mm	L1 mm	L2 mm	g	mm	€
50813471080	T 10	2,74	125	100	75	27	5	2,80
50813471580	T 15	3,27	125	100	75	28	5	2,80
50813472080	T 20	3,86	125	100	75	28	5	2,80
50813472580	T 25	4,43	130	100	95	62	5	3,10
50813472780	T 27	4,99	130	100	95	63	5	3,30
50813473080	T 30	5,52	235	200	95	85	5	3,30
50813474080	T 40	6,65	235	200	95	123	5	3,90
50813474580	T 45	7,82	285	250	95	142	5	4,10
50813475080	T 50	8,83	290	250	115	315	5	5,40

Juego de destornilladores TORX®

Jeu de tournevis TORX®

Set of TORX® Screwdrivers

TORX®-Schraubendrehersatz

en soporte metálico 195 x 120 x 290 mm, con agujeros para colgar, de 9 pzs., acero al cromo vanadio

en coffret métallique 195 x 120 x 290 mm 9 pces., avec trou de suspension acier au Chrome Vanadium

in metal holder 195 x 120 x 290 mm 9 pcs., with hang-up hole Chrome-Vanadium

im Metallhalter 195 x 120 x 290 mm, 9-tlg., mit Aufhängebohrungen, Chrom-Vanadium

H 5081347-9



Bestell-No. Order-No.	Art.No.	★	g	mm	€
50813470080	5081347-9	T 10 · T 15 · T 20 · T 25 · T 27 · T 30 · T 40 · T 45 · T 50	1245	1	39,50

Juego de destornilladores TORX®

Jeu de tournevis TORX® coudés

Set of L-shaped TORX® Wrenches

TORX®-Winkelschraubendrehersatz

en soporte plegable, plastificadas, para tornillos TORX interiores, acero especial

sur monture, revêtement plastique, pour vis TORX intérieures acier spécial

in metal holder, plastic coated for TORX socket screws special steel

im Handklapphalter, kunststoffbeschichtet, für Innen-TORX®-Schrauben Spezial Stahl

H 5081348-7

Lieferung in Blisterverpackung supplied in blister packing



Livré sous blister Suministro en envase blisterizado

Bestell-No. Order-No.	Art.No.	★	g	mm	€
50813486280	5081348-7	T 10 · T 15 · T 20 · T 25 · T 27 · T 30 · T 40	245	1	7,50



**TORX®-
Winkelschraubendrehersatz**

9-tlg., im Kunststoffhalter,
für Innen-TORX®-Schrauben
Spezial Stahl

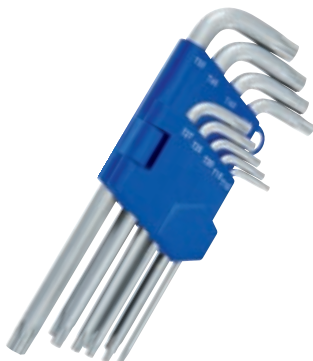
HP 5081348-9

**Set of L-shaped
TORX® Wrenches**

9 pcs., in plastic holder for
TORX socket screwsspecial steel

**Jeu de tournevis
TORX® coudés**

9 pces., sur monture plastique,
pour vis TORX intérieures
acier spécial

**Juego de destornilladores
TORX®**

De 9 pzs., en soporte de plástico,
para tornillos TORX interiores,
acero especial



Lieferung in Blisterverpackung
supplied in blister packing
Livré sous blister
Suministro en envase blisterizado

Bestell-No. Order-No.	Art.No.				€
50813488280	5081348-9	T 10 · T 15 · T 20 · T 25 · T 27 T 30 · T 40 · T 45 · T 50	316	1	10,75

Schlosserhämmer

Fiberglasstiel mit Kunststoff-Schutzüberzug,
Kopf schwarz lackiert

5081523 - 5081528

Engineers' hammer

Fibreglass handle with plastic
coating, black lacquered head



Marteau de mécanicien

Manche en fibre de verre avec
protection plastique, tête laquée noir

Martillo de peña

Mango de fibra de vidrio plastifica-
do, cabeza pintada de negro



Bestell-No. Order-No.	Art.No.				€
50815230021	5081523	300	500	1	10,25
50815250021	5081525	500	700	1	13,50
50815280021	5081528	800	1000	1	18,25

Ganzstahl-Latthammer

mit kariert-gefräster Bahn,
eingeschmiedetes Nagelbett
mit Magnethalterung,
2-K Kunststoffgriff,
Kunststoffschutzkappe an der Pinne

5081516

NEW
**whole steel carpenter hammer
with draughted milled face,
built-in forged**

magnetic nail holder slider,
2-components plastic handle,
peen protected with a
plastic sleeve

**marteau de charpentier tout
acier avec face fraisée
en gaufre**

glissière pour clou incorporée et
forgée avec maintien magnétique,
poignée à 2composantes, pointe
protégée par un manchon en
plastique

**martillo de carpintero,
enteramente de acero**

con cara grafilada, canal imantado
de sujeción de clavos, mango de
plástico de dos componentes,
funda de protección de plástico
para la uña



Bestell-No. Order-No.	Art.No.				€
50815160021	5081516	600	925	1	39,00

Maza

Masse

Club hammer

Fäustel

Mango de fibra de vidrio plastificado, cabeza pintada de negro

Manche en fibre de verre avec protection plastique tête laquée noir

Fibreglass handle with plastic coating, black lacquered head

Fiberglasstiel mit Kunststoff-Schutzüberzug, Kopf schwarz lackiert



5081518



Bestell-No. Order-No.	Art.No.	g	Ø mm			€
50815181021	5081518	1000	260	1290	1	14,60

Bolsa de herramientas, enrollable

Trousse à outils

Tool wallet, empty

Werkzeugrolltasche

Bolsa enrollable, vacía, con 15 bolsillos, de poliéster negro, bordes de polipropileno azul marino, con cinta y hebilla, neutral

Trousse, sans outils, à 15 compartiments, en polyester noir, bords bleu foncé avec lanière et boucle, sans impression

With 15 compartments made from black polyester with dark blue lining with strap and clasp, neutral

Rolltasche, o. Inhalt, mit 15 Facheinteilungen, gefertigt aus schwarzem Polyester, PP-Einfassung in dunkelblau, mit Gurt und Schnalle. Ohne Aufdruck.

9088070



Bestell-No. Order-No.	Art.No.	Maße · Dimensions · Medidas			€
90880701500	9088070	670 x 340 mm	750	5	8,30

Llave de tubo de boca triangular

Clé en tube triangulaire

Tubular Triangular Wrench

Dreikant-Rohrsteckschlüssel

con bandeador, triángulo normalizado para M10 y M12, DIN 3222 / 3223

avec broche triangle pour M 10 et M 12 DIN 3222 / 3223

with tommy bar for standard M10 and M12 triangulars DIN 3222/3223

mit Drehstift, Normdreikant für M10 und M12 DIN 3222 / 3223

50898



speziell für Rettungskräfte und Hausmeister
in particular for rescue services and caretakers
spécial pour services de secours et concierges
especial para equipos de salvamiento y mantenimiento

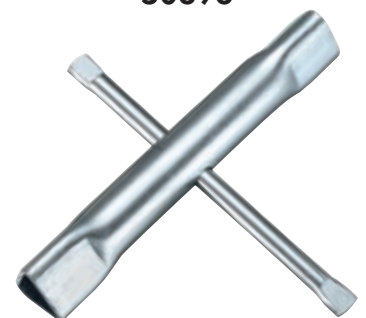

Bestell-No. Order-No.	Art.No.	Ø mm			€
50898101260	50898	140 x 125	175	1	11,75

Montiereisen

mit auswechselbarer
Kunststoffschiene

5081500



Tyre Lever

with exchangeable plastic cover

avec gaine plastique amovible

Desmontable

con regla de plástico intercambiable



Die auswechselbare Kunststoffschiene schützt
Aluminium- und lackierte Felgen vor Beschädigung

The exchangeable plastic cover protects aluminium
and painted wheels from damage

La gaine en plastique amovible protège les jantes
alu et en tôle

La regla de plástico protege llantas de aluminio o
pintadas de raspaduras

Bestell-No. Order-No.	Art.No.	Ø mm	g	1	€
50815003880	5081500	380	415	1	29,00

Ersatzschiene
für Montiereisen

5081501

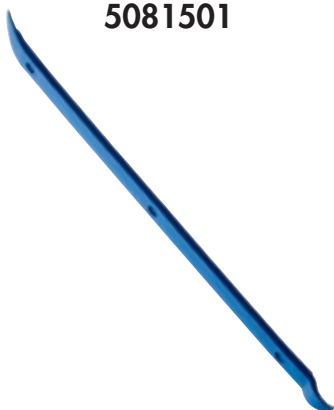
Spare cover for
tyre leverGaine plastique de rechange
pour démonte-pneusRegla de recambio para
desmontable

Befestigungsschrauben sind nicht im Lieferumfang

fixing screws do not belong to scope of supply

les vis de fixation ne sont pas incluses

No se incluyen los tornillos de sujeción

Bestell-No. Order-No.	Art.No.	Ø mm	g	1	€
50815013800	5081501	380	55	1	14,50

Rohrabschneider

Für Kupfer, Messing, Leichtmetall und
dünnwandiges Stahlrohr.
Mit ausklappbarem Entgratungsmesser im
Handgriff, für Rohre von 3 bis 28 mm
(1.1/8"), 275 x 120 x 30 mm

5081640



Tube Cutter

Coupe-tube

Cortatubos

For copper, brass, light metal and
thin walled steel tubes
swivelling deburrer incorporated in
frame, for tubes from 3 to 28 mm,
(1.1/8"), 275 x 120 x 30 mm

Pour cuivre, laiton, aciers non-ferreux
et tubes fins en acier.
Avec lame d'ébarbage dans la poi-
gnée, pour tubes de 3 à 28 mm
(1.1/8"), 275 x 120 x 30 mm

Para tubos de cobre, latón,
aleaciones ligeras y de acero de
pared delgada. Con cuchilla para
rebarbar incorporada al mango,
para tubos de 3 - 28 mm de
diámetro (1.1/8"),
275 x 120 x 30 mm

Bestell-No. Order-No.	Art.No.	für · for · pour · para Ø	g	1	€
50816402820	5081640	3 - 28 mm	145	1	8,50

cortatubos de carraca

Coupe-tube à cliquet

ratchet tube cutter

Knarren-Rohrabschneider

capacidad de corte de 26 a 67 mm y grosor de pared hasta 3 mm, también apto para cortar acero inoxidable, especial para trabajar en espacios estrechos

capacité de coupe de 28-67 mm, jusqu'à 3 mm de section, convient aussi aux aciers inox, spécial pour accès de travail restreints

cutting range from 28-67 mm, till 3 mm thickness, also convenient for stainless steel, special for restricted working areas

Schneidkapazität von 28-67 mm, bis 3 mm Wandstärke, auch für Nirosta-Stähle geeignet, speziell für enge Arbeitsbereiche



5081643

NEW

* Ersatz-Schneiderad · Replacement cuttingwheel · Roulette de coupe de rechange · rueda de corte de recambio

Bestell-No. Order-No.	Art.No.	Ø mm	⊖ ⊕	g	⊞	€
50816436700	5081643	250	120	1010	1	129,00
50816430100	5081643-1		16	5	1	4,85

Carraca,
sin cuadradillo

DIN 3122 C,
Cromo Vanadio, cromadas

Cliquet,
sans carré conducteur

DIN 3122 C,
Chrome-vanadium, chromium plated

Ratchet,
without square coupler

DIN 3122 C,
Chrome-vanadium, chromium plated

Durchsteckknarre
ohne Verbindungsvierkant

DIN 3122 C,
Chrom-Vanadium, verchromt

50750-01-1



Bestell-No. Order-No.	Art.No.	Ø mm	g	⊞	€
50750010180	50750-01-1	260	430	5	18,90

Llaves escalonadas

Cromo Vanadio, cromadas
Llaves combinadas para montar y desmontar valvulas de radiador, racores de retorno y sxtensions de grifo cortos

Cle etagee

Chrome-Vanadium, chromés
Pour le montage et le demontage de raccords de soupapes

Combination stepped key

Chrome-vanadium, chromium plated
for pin, hexagon and double hexagon drivers, for installing and removing radiation valves, run-back srewes and short tap extensions

Stufenschlüssel

Chrom-Vanadium, verchromt
für Ein- und Ausbau von Heizkörperventilnippeln, Rücklauf verschraubungen und kurzen Hahnverlängerungen



90050-4



Bestell-No. Order-No.	Art.No.	Ø mm	g	⊞	€
90050400080	90050-4	90	120	1	19,50

Stufenschlüsselsatz

Set of stepped wrenches and ratches

Jeu cliquet et clé étagée

Conjuntos de llaves escalonadas con carraca

in Kunststoffschraubverpackung

in screw cap plastic tube

en étui plastique cylindrique

en tubo de plástico con tapa a rosca

58103

Bestell-No.
Order-No.

Art.No.

mm

g

€

58103000100

58103

290

610

1

37,00

Spezial-Kardangelnk

Universal Joint, special

Cardan universel spécial

Articulación universal especial

Chrom-Vanadium, verchromt,
beide Antriebsseiten mit InnenvierkantChrome-vanadium, chromium plated,
with two female squaresChrome-Vanadium, chromés,
les deux côtés d'entraînement
avec carré intérieurCromo Vanadio, cromadas,
ambos lados con cuadradillo hembra

98263-06

Bestell-No.
Order-No.

Art.No.

mm

g

€

98263060080

98263-06

65

180

1

14,50

Verbindungsvierkant

Square coupler

Carre conducteur

Adaptador

Chrom-Vanadium, verchromt,
für 1/2" VerbindungenChrome-vanadium, chromium plated,
for 1/2" connectionsChrome-Vanadium, chromés,
pour 1/2" connexionsCromo Vanadio, cromadas,
para 1/2" conexions

90050-16

Bestell-No.
Order-No.

Art.No.

mm

g

€

90050160083

90050-16

37

45

10

3,35

Express-Schlüssel

Sanitary wrench

Cle express

Llaves para tornillos tipo Express

Chrom-Vanadium, verchromt,
Montageschlüssel für Express- und
Stockschrauben, Mittelstück mit
Innengewinde für Stockschrauben M 10,
für Waschtischbefestigungen und
EckventilmontagenChrome-vanadium, chromium plated,
for bathroom fittings attachment
(metric screws)Chrom-Vanadium, chromés,
pour le montage et le demontage
de vis d'arrêt de fixation de lavabo,
patte vis, montage d' equerre.
Partie mediane avec filetage et
bille integre pour vis M 10Cromo Vanadio, cromadas,
Llaves para montar tornillos tipo Ex-
press y Stock, pieza central con
roscas interior para tornillos Stock M 10,
para montar lavabos y válvulas,
para montar tornillos Stock M 10

50958

Bestell-No.
Order-No.

Art.No.

mm

g

€

50958171980

50958

17 x 19

223

265

5

18,90

Conjunto para fontaneros
11 pzs.

Jeu d'outils « sanitaire »
11 pces.

Sanitary Tool Set
11 pcs.

Sanitär-Garnitur
11-tlg.

Cromo Vanadio, cromadas,
en casa metálica

Chrome-Vanadium, chromées,
en coffret métallique

Chrome-vanadium, chromium plated,
in metal case

Chrom-Vanadium, verchromt,
in Metallkasten

50780



Bestell-No. Order-No.	Art.No.	CLD mm			€
50780809580	50780	318 x 119 x 49		1	98,00

enthaltend · containing · composition · contenido



		MM 10-13-17-19-21		90 mm
		260 mm		MM 6
		MM 17 x 19		34 mm
		125 mm		



Llaves para tuerca
de lavabo

Cle lavabo

Basin Wrench

Standhahnmutternschlüssel

Cromo Vanadio, barnizado,
forjadas, muy robustas, manivela
articulada, con garra articulada
y con muelle, para montar y
desmontar

Chrome-Vanadium, laqués,
avec manche et machoire articulée
pour un maniement aisé.
Fonctionnement droite/gauche

Chrome-vanadium, lacquered,
with pivoted hook for right-hand
or left-hand operation

Chrom-Vanadium, lackiert,
gesenkgeschmiedet, sehr robust,
schwenkbarer Quergriff, mit schwenkbarer,
gefederter Klaue für Rechts- und Linksgang



90950



Bestell-No. Order-No.	Art.No.	mm	Ø	AF	CLD mm			€
90950103220	90950	10 - 32	3/8"	1.1/4"	240	520	2	26,00

Llaves en cruz
para fontanero

Cle sanitaire en croix

Sanitary Cross Wrench

Sanitärkreuzschlüssel

barnizado,
Llaves especiales para fontanería,
pintadas en epoxi, para montar y
desmontar extensiones de grifos,
3/8" - 1/2" - 3/4" - 1",
para tornillos tipo Express
M 8 - M 10 - M 12

laqués,
pour le montage et le démontage:
de robinets 3/8" - 1/2" - 3/4" - 1"
de vis d'arrêt de fixation de lavabo
M 8 - M 10 - M 12

lacquered,
Special Wrench for sanitary installation.
For valve extensions
3/8" - 1/2" - 3/4" - 1"
Boits: M 8 - M 10 - M 12

lackiert,
Spezialschlüssel für die Sanitärtechnik,
zum Ein- und Ausbau von Hahnverlängerun-
gen 3/8" - 1/2" - 3/4" - 1" und
Express Schrauben M 8 - M 10 - M 12

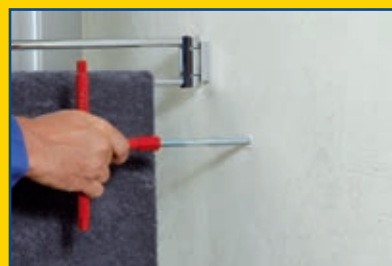

90955



Bestell-No. Order-No.	Art.No.		MM	CLD mm			€
90955020020	90955		10 · 12 · 17 · 22	200 x 200	520	5	24,00

Sicherheits-Klappsäge

Safety Pruning Saw

Scie de sécurité rabattable,
repliable

sierra plegable

Blatt aus hochwertigem Carbon-Stahl,
Klemmschutz, Daumendruckplatte,
2-K-Griff, 2-stufige Klappsperre,
Schnittlänge bis 100 mm,
3-fach Zahnschliff

High carbon steel blade,
squeeze protection, thumb pressure
plate, 2-components plastic handle,
two-stage folding lock, cutting-length
100 mm, teeth with triple grinding

Lame en acier-carbone de haute
qualité, clapet de sécurité, plat
pour pression du pouce, poignée
à 2 composants, 2 crans d'arrêt,
longueur de coupe jusqu'à
100 mm, denture à 3 faces

hoja de acero al carbono,
protección contra contusiones,
apoyo de presión, mango de
plástico de 2 componentes,
bloqueo de cierre de 2 escalones,
largo de corte hasta 100 mm,
afilado dentado triple

5081611

Bestell-No.
Order-No.

Art.No.

CLO
mm

g

1

€

50816110000

5081611

400

200

1

12,50

Ausstellungs- und
VerkaufslochwändeExhibition and
Sales DisplaysPrésentoirs perforés pour
exposition et vente

Paneles para expositores

Verkaufsfördernde Maßnahmen

Mit unseren Verkaufswänden erfüllen
wir den gehobenen Anspruch von
Händler und Anwender

Measures for Sales Promotion
our displays fulfil highest demands
of traders and users

Mesures d'aide à la vente

Nos présentoirs de vente correspon-
dent aux plus hautes exigences des
revendeurs et utilisateurs.

Actividades promocionales

Con nuestros expositores
satisfacemos las altas exigencias
de revendedores y usuarios

Auf Anfrage stellen wir Ihnen gerne
eine auf Ihre Bedürfnisse zugeschnittene
Präsentation zur Verfügung

A suitable presentation meeting
your particular requirements
can be provided on demand

Sur demande, nous vous préparerons
volontiers un modèle de présentation
en fonction de vos souhaits.

Previa consulta, les diseñamos
expositores a la medida de sus
necesidades

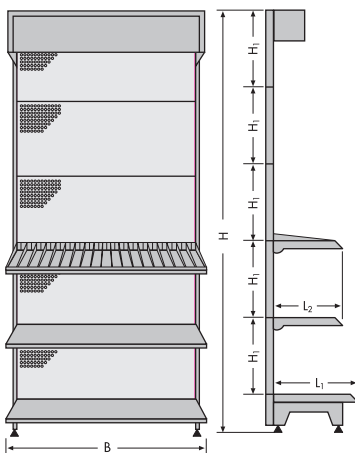

B = 665 · 1000 · 1250 · 1333 mm

H = 1410 · 1610 · 2010 · 2210 ·
2410 mmH₁ = 400 mmL₁ = 570 mmL₂ = 250 · 300 · 370 · 470 mm

Lista de referencias		Liste des references		Numerical List		Nummernliste	
Art.-No.	Seite page	Art.-No.	Seite page	Art.-No.	Seite page	Art.-No.	Seite page
50253	50	H 5081340-7	56	50850-52	27	M 50829-4	37
50720	7	HP 5081343-9	56	50850-53	28	M 50829-5	39
K 50720	7	5081347	57	50850-54	29	M 50829-8	38
M 50720	7	H 5081347-9	57	50850-55	27	M 50829-9	39
R 50720	7	H 5081348-7	57	50850-56	28	M 50829-10	38
50725	8	HP 5081348-9	58	50850-59	29	M 50829-11	38
K 50725	8	M 50829-33	45	50851-3015	31	M 50829-12	38
M 50725	8	M 50829-34	45	50853-3015	31	M 50829-13	37
R 50725	8	M 50829-35	45	50855-00-15	18	M 50829-14	38
50730	9	50829-3017	25	50855-04-1	18	M 50829-15	40
R 50730-3	9	50830	53	50855-6	18	M 50829-16	40
50740	9	50833-2	12	5081424	54	M 50829-17	40
50750-01-1	61	50839	3	5081440	53	M 50829-30	45
50780	63	K 50839-3	3	5081494	52	M 50829-31	45
50800	2	50840-00-15	15	5081500	60	M 50829-32	45
B 50800	2	50840-03	15	5081501	60	50855-16	18
K 50800	2	50840-04	15	5081516	58	50855-3015	30
R 50800	2	50840-04-1	15	5081518	59	50860-3015	32
HP 50800	2	50840-06	15	5081523	58	5086300	49
50800-3306	11	50840-6	16	5081525	58	5086300-3	49
50805	6	50840-10-15	15	5081528	58	5086300-B	48
K 50805	6	50840-12	7	5081611	64	5086300-19	49
R 50805	6	50840-14	15	5081621-1	52	5086300-19-3	49
HP 50805	6	50840-15	15/17	5081640	60	5086300-19-B	48
5080542	55	50840-19-1	16	5081643	61	50868	41
R 5080542-9	55	50840-19-3	16	5081720	52	50868-1	42
508076-945	44	50840-3015	26	5081730	52	50868-2	42
50810	4	50843-3015	26	5082250	53	50868-3	43
B 50810	5	5084511	54	50825-00-15	11	50870-3015	33
K 50810	5	5084512	54	50825-03	11	50870-3115	33
R 50810	5	5084530	54	50825-04	11	50872-3015	33
HP 50810	5	5084536	54	50825-05	11	50873-3015	33
508100-00-6	22	50850-00-15	17	50825-05-5	11	50880	46
508100-03	22	50850-03	17	50825-06	11	50882	46
508100-04	22	50850-04	17	50825-08	11	50884-3015	30
508100-04-1	22	50850-04-5	17	50825-6	13	50885	46
508100-05	22	50850-05	17	50825-10-15	11	50890-10	47
508100-6	23	50850-05-5	17	50825-12	7	50890-20	47
508101-310	34	50850-06	17	50825-19	13	50898	59
5081129	35	50850-6	19	50825-20	13	50958	62
5081129-15	35	50850-10-15	17	50825-20-15	11	58103	62
5081129-25	36	50850-12	7	50825-30	14	90050-4	61
5081129-28	36	50850-14-1	15/17	50825-31	14	90050-16	62
5081200	50	50850-19	19	50825-32	14	9083312-3	12
5081208	50	50850-19-1	19	50825-33	14	9088070	59
5081209	50	50850-19-3	19	50825-35	14	90950	63
5081212	51	50850-20	20	50825-37	14	90955	63
5081213	51	50850-31	20	50825-3015	25	98076-08	44
5081241	51	50850-33	20	50825-5015	32	98263-06	62
5081280	51	50850-34	21	50828-3010	25		
5081338	55	50850-36	21	M 50829-2	39		
H 5081338-8	56	50850-37	21	M 50829-3	37		

Nummernliste		Numerical List		Liste des references		Lista de referencias	
Code	EAN 4024089 +	Code	EAN 4024089 +	Code	EAN 4024089 +	Code	EAN 4024089 +
50253320834	058260	50800944080	171198	50810064180	331707	50825040083	329889
50720008080	123869	50800947080	171181	50810064680	331714	50825050083	329896
50720009080	123852	50805060780	324204	50810065080	331721	50825055083	350104
50720010080	123845	50805080980	324228	50810131080	329254	50825060083	329902
50720011080	123838	50805101180	324235	50810627380	345896	50825080083	329919
50720012080	123821	50805121380	324242	50810724280	325188	50825101500	313451
50720013080	123814	50805141580	324259	50810727180	307986	50825121083	323948
50720014080	123807	50805161780	324266	50810727280	307962	50825190683	329926
50720015080	123791	50805181980	324273	50810729480	339574	50825190783	329933
50720016080	123784	50805202280	324280	50810824280	174175	50825190883	329940
50720017080	123777	50805212380	324297	50810827180	174151	50825190983	329957
50720018080	123760	50805242780	324303	50810924280	171143	50825191083	329964
50720019080	123753	50805252880	324310	50810927180	171150	50825191183	329971
50720600080	125818	50805303280	324327	50810927280	311105	50825191283	329988
50720600180	128895	50805420680	347494	50810929080	171167	50825191383	329995
50720600280	133394	50805420780	347500	50810929480	171174	50825191483	331028
50720600380	325560	50805420880	347517	50811290120	326604	50825200483	345933
50725008080	169911	50805420980	347524	50811291500	341997	50825200583	345940
50725009080	169928	50805421080	347531	50811292500	342079	50825200683	345957
50725010080	169935	50805421180	347548	50812001842	345261	50825200783	345964
50725011080	169942	50805421280	347555	50812082042	345223	50825200883	345971
50725012080	169959	50805421380	347562	50812092042	345230	50825201083	345988
50725013080	169966	50805425580	347487	50812121842	345254	50825201183	345995
50725014080	169973	50805429080	356267	50812131642	345247	50825201583	350111
50725015080	169980	50805644080	347654	50812412213	332179	50825300383	330007
50725016080	169997	50805747080	331844	50812802550	356144	50825300483	330014
50725017080	170009	50805944080	324334	50813380080	347586	50825300583	331035
50725018080	170016	50805947080	324341	50813380280	347319	50825301583	328646
50725019080	170023	50807694500	346633	50813380380	347333	50825310183	330021
50725022080	170030	50810000680	331776	50813380480	347340	50825310283	330038
50725024080	170047	50810003080	331769	50813380580	347357	50825310383	330045
50725600080	174571	50810004080	331745	50813380680	347364	50825310483	330052
50725600180	174588	50810004180	331738	50813380880	347371	50825320183	331042
50725600280	174953	50810005080	331752	50813381080	347388	50825320283	331059
50725600380	304428	50810006080	170917	50813382580	347326	50825320383	331066
50730081383	348224	50810007080	170900	50813406280	347067	50825330183	331103
50730091583	348231	50810008080	170894	50813438280	347074	50825330283	331097
50730161983	348248	50810009080	170887	50813470080	347593	50825330383	331110
50730202483	348255	50810010080	170870	50813471080	347395	50825350183	330069
50730600183	348262	50810011080	170863	50813471580	347401	50825350283	330076
50740192236	166941	50810012080	170856	50813472080	347418	50825350383	331127
50750010180	061963	50810013080	170849	50813472580	347425	50825370883	331141
50780809580	339086	50810014080	170832	50813472780	347432	50825371083	331134
50800060780	170597	50810015080	170825	50813473080	347449	50825371583	330083
50800080980	170603	50810016080	170818	50813474080	347456	50825372083	330090
50800081080	325805	50810017080	170801	50813474580	347463	50825372583	330106
50800101180	170610	50810018080	170795	50813475080	347470	50825372783	330113
50800101380	173697	50810019080	170788	50813486280	347050	50825373083	330120
50800111380	314014	50810020080	170771	50813488280	347043	50825374083	331158
50800121380	170627	50810021080	170764	50814240050	306682	50825501583	328639
50800131580	325829	50810022080	170757	50814400000	356762	50825600483	330137
50800131780	325836	50810024080	170740	50814941500	327106	50825600583	330144
50800141580	170634	50810027080	170733	50815003880	334357	50825600683	330151
50800161780	170641	50810030080	170726	50815013800	334364	50825600783	330168
50800161880	325843	50810032080	170719	50815160021	353747	50825600883	330175
50800171980	173680	50810061980	331578	50815181021	331547	50825600983	330182
50800181980	170658	50810062180	331585	50815230021	326208	50825601083	330199
50800192280	325850	50810062280	331592	50815250021	326215	50825601183	330205
50800202280	170665	50810062380	331608	50815280021	326222	50825601283	330212
50800212380	170672	50810062480	331615	50816110000	353334	50825601383	330229
50800242780	170689	50810062680	331622	50816210132	356410	50825601483	330236
50800252880	170696	50810062780	331639	50816402820	332148	50825601583	331165
50800273080	173673	50810062980	331646	50816436700	353105	50825604583	330243
50800303280	170702	50810063080	331653	50817200000	356847	50825605583	330250
50800330683	332353	50810063280	331660	50817300000	356830	50828301083	346169
50800644080	345902	50810063580	331677	50822500780	356786	50829000280	332131
50800747080	334012	50810063680	331684	50825015083	329872	50829000380	332117
50800844080	174168	50810063880	331691	50825030083	331011	50829000480	332100

Lista de referencias		Liste des references		Numerical List		Nummernliste	
Code	EAN 4024089 +	Code	EAN 4024089 +	Code	EAN 4024089 +	Code	EAN 4024089 +
50829000500	332124	50850050083	330540	50850340183	349528	50850602383	331301
50829000880	332162	50850055083	350098	50850340283	349535	50850602483	330779
50829000980	332155	50850060083	330557	50850340383	349542	50850602783	330786
50829001033	332292	50850101500	313475	50850340483	349559	50850603083	330793
50829001100	332094	50850121983	323962	50850340583	349566	50850603283	330816
50829001283	332193	50850141083	331219	50850340683	349573	50851301583	328677
50829001383	332209	50850190183	330564	50850340783	349580	50853301583	328660
50829001483	332285	50850190383	330571	50850342183	349597	50855015083	350074
50829001542	348163	50850191083	330588	50850342283	349603	50855041083	350067
50829001680	350241	50850191383	330595	50850342383	349610	50855160083	350050
50829001783	350654	50850191483	330601	50850342483	349627	50855301583	346183
50829003083	346602	50850191583	330618	50850342583	349634	50855601083	349931
50829003100	346572	50850191783	330625	50850342683	349641	50855601183	349948
50829003200	346589	50850191983	330632	50850342783	349658	50855601283	349955
50829003380	346619	50850192283	331226	50850360383	349825	50855601383	349962
50829003480	346596	50850192483	331233	50850360483	349832	50855601483	349979
50829003580	346626	50850201083	346008	50850360683	349849	50855601583	349986
50829301783	353099	50850201183	346015	50850360883	349856	50855601783	349993
50830000000	356854	50850201283	346022	50850361083	349429	50855601983	350005
50833200000	327465	50850201483	346039	50850361183	349436	50855602183	350012
50839000100	202571	50850201683	346046	50850361283	349443	50855602283	350029
50839000680	176940	50850201883	346053	50850361383	349450	50855602483	350036
50839000880	176933	50850202083	346060	50850361483	349467	50860301580	318913
50839001080	177206	50850202283	346077	50850361583	349474	50863000300	331790
50839001280	313512	50850202483	346084	50850361683	349481	50863001730	356816
50840015083	330267	50850310083	349276	50850361783	349498	50863001760	332001
50840030883	332360	50850310183	349283	50850361883	349504	50863001930	356823
50840040083	330274	50850310283	339819	50850361983	349511	50863001960	332018
50840041083	331189	50850310383	339826	50850362083	349320	50863002160	332025
50840060083	330281	50850310483	339833	50850362583	349337	50863190300	331806
50840101500	313444	50850310583	339840	50850362783	349344	50863191730	356793
50840121383	323955	50850310683	339857	50850363083	349351	50863191760	332032
50840140083	330298	50850310783	349290	50850364083	349368	50863191930	356809
50840150083	330328	50850310883	349306	50850364583	349375	50863191960	332049
50840190183	330335	50850310983	349313	50850365083	349382	50863192160	332056
50840190383	330953	50850311083	350159	50850365583	349399	50868000000	355086
50840301583	328653	50850311183	339987	50850366083	349405	50870301583	341935
50840600883	330359	50850311283	339970	50850367083	349412	50870311583	341942
50840600983	330366	50850311383	350128	50850372083	340020	50872301583	348590
50840601083	330373	50850311483	339956	50850372583	340037	50873301583	348583
50840601183	330380	50850311583	339963	50850372783	340044	50880000080	348156
50840601283	330397	50850311683	350135	50850373083	331240	50882000080	307337
50840601383	330403	50850311783	350142	50850374083	331257	50884301583	346176
50840601483	330410	50850311883	339994	50850374583	331264	50885000080	176957
50840601583	330427	50850311983	350166	50850375083	331271	50890100100	306705
50840601683	330434	50850312283	350173	50850375583	349801	50890200200	327144
50840601783	330458	50850312483	350180	50850376083	349818	50890300200	339567
50840601883	330472	50850312583	350197	50850520083	346350	50898101260	339550
50840601983	330489	50850312683	350203	50850530083	346367	50958171980	144185
50840602083	331196	50850312783	350210	50850540083	346374	58103000100	164336
50840602183	330496	50850330183	349665	50850551283	346398	90050160083	074857
50840602283	330502	50850330283	349672	50850560283	346428	90050400080	142389
50840602483	331202	50850330383	349689	50850590083	346411	90833120305	331530
50843301580	316902	50850330483	349696	50850600883	331288	90880701500	331486
50845110180	326468	50850330583	349702	50850600983	331295	90950103220	144192
50845110280	326475	50850330683	349719	50850601083	330649	90955020020	144215
50845120133	332261	50850330783	349726	50850601183	330656	98076080020	089257
50845120233	332278	50850331283	349894	50850601283	330670	98263060080	090949
50845300480	326437	50850331483	349900	50850601383	330687		
50845305580	326444	50850331583	349917	50850601483	330694		
50845306580	326451	50850331683	349863	50850601583	330700		
50845361033	332230	50850332183	349733	50850601683	330823		
50845361233	332247	50850332283	349740	50850601783	330717		
50845367533	332223	50850332383	349757	50850601883	330724		
50850015083	330519	50850332483	349764	50850601983	330731		
50850030083	332377	50850332583	349771	50850602083	330748		
50850040083	330526	50850332683	349788	50850602183	330755		
50850045083	350081	50850332783	349795	50850602283	330762		

Verkaufs-, Lieferungs- und Zahlungsbedingungen

1. Anerkennung der Verkaufs-, Lieferungs- und Zahlungsbedingungen

Unsere Verkäufe basieren auf den nachstehenden Bedingungen, wobei jeweils nur die neuesten Verkaufsunterlagen Gültigkeit besitzen. Abweichungen oder mündlich getroffene Nebenabsprachen bedürfen unserer schriftlichen Bestätigung. Bedingungen der Besteller können wir nicht anerkennen, auch dann nicht, wenn von uns nicht ausdrücklich widersprochen wird. Der Besteller erkennt durch die Erteilung seines Auftrages unsere Bedingungen an. Vertragsgültigkeit wird erst durch unsere schriftliche Auftragsbestätigung erreicht.

2. Angebote

Unsere Angebote sind freibleibend, Katalog und Preisliste sind Bestandteil unseres Angebotes. Maß- und Gewichtsangaben sowie Abbildungen, Leistungsbeschreibungen, technische Zeichnungen und Daten sind unverbindlich, sofern sie nicht ausdrücklich als verbindlich bestätigt werden, sie können jederzeit und ohne besondere Anzeige geändert werden.

3. Schutzrechte

Werkseigene Zeichnungen, Abbildungen, Photos und sonstige Unterlagen bleiben auch nach Weitergabe an den Besteller oder an Dritte unser Eigentum und unterliegen dem Urheberrecht. Ohne unsere Erlaubnis dürfen diese weder vervielfältigt noch anderen zugänglich gemacht werden. Sie sind an einem sicheren Ort aufzubewahren und auf Verlangen an uns zurückzugeben. Werden bei der Anfertigung von Waren nach Zeichnungen, Mustern bzw. sonstigen Angaben des Bestellers Schutzrechte Dritter verletzt, so stellt dieser uns von sämtlichen Ansprüchen frei.

4. Sonderanfertigungen

Bei Sonderanfertigungen behalten wir uns das Recht einer Mehr- bzw. Mindertlieferung bis zu 10 % vor. Hierzu zählen ebenfalls Serienteile, die auf ausdrücklichen Wunsch des Bestellers besonders zu zeichnen sind. Der Besteller kann nicht vom Auftrag zurücktreten; besonders hergestellte oder gezeichnete Ware wird von uns nicht zurückgenommen.

Im Falle von Zahlungsunfähigkeit bzw. Konkurs des Bestellers behalten wir uns das Recht vor, die Ware direkt zu verkaufen. Bei Herstellung nach Unterlagen des Bestellers haftet dieser für die Richtigkeit seiner Zeichnungen, Muster, Lehren usw. Muster werden grundsätzlich nur gegen Berechnung geliefert.

5. Preise

Unsere Preise sind freibleibend in EUR und als unverbindliche Preisempfehlung anzusehen. Sie verstehen sich einschließlich Mehrwertsteuer, wobei der am Tage der Lieferung gültige Mehrwertsteuersatz Anwendung findet.

Eine Berichtigung unserer Preise behalten wir uns vor, sofern bis zum Tage der Lieferung Änderungen in den Grundkosten, wie Rohmaterial, Energie, Löhne usw. eintreten. Lieferungen erfolgen grundsätzlich in den im Katalog genannten Verpackungseinheiten. Kleinere oder durch die Verpackungseinheiten nicht teilbare Mengen werden lose in Papier verpackt und mit einem Aufschlag von 25 % belastet, sofern in unseren Verkaufsunterlagen kein anderweitiger Vermerk gemacht wird.

6. Zahlungsbedingungen

Unsere Rechnungen sind zahlbar Inland: 10 Tage nach Rechnungsdatum abzüglich 2 % Skonto oder 30 Tage nach Rechnungsdatum netto, falls keine anderen Vereinbarungen getroffen wurden.

Ausland: Nach besonderen Vereinbarungen; maßgebend ist der Zahlungsvermerk auf dem jeweiligen Angebot, der Proforma-Rechnung bzw. der Rechnung. Beträge unter EUR 25,- netto sind grundsätzlich nicht skontoberechtigt. Wechsel werden nur nach vorheriger Vereinbarung hereingenommen. Die Kosten der Diskontierung und Einziehung trägt grundsätzlich der Besteller. Bei Zahlungsverzug oder Stundung belasten wir Zinsen in Höhe von 2 % über dem zu diesem Zeitpunkt gültigen Diskontsatz der Deutschen Bundesbank. Die Wertstellung eingegangener Schecks und Wechsel erfolgt zu dem Tag, an dem wir über den Gegenwert verfügen können. Sollte uns nach Vertragsabschluss Umstände bekannt werden, welche die Kreditwürdigkeit des Kunden beeinträchtigen, sind wir berechtigt, Vorauszahlung oder andere Sicherheitsleistungen zu verlangen. Eine Zurückhaltung der Zahlung wegen Minderungs-, Wandlungs-, oder eventueller anderer Gegenansprüche, sowie die Aufrechnung mit solchen ist nicht zulässig.

7. Lieferung und Versand

Wenn nicht anders vereinbart, liefern wir grundsätzlich ab Werk ausschließlich Verpackung, wobei Lieferung und Versand der Ware auf Gefahr des Bestellers erfolgen. Versicherungen gegen Diebstahl, Transportschäden usw. erfolgen nur auf Wunsch und Kosten des Bestellers. Falls keine besondere Vorschrift gegeben wird, wählen wir den günstigsten Versandweg.

Waren, die zu einem vereinbarten Termin versandbereit gemeldet werden, müssen umgehend abgerufen werden, da wir andernfalls berechtigt sind, diese auf Kosten und Gefahr des Bestellers zu lagern und als geliefert zu berechnen. Für Verladungen setzen wir Netto - Mindestauftragswerte wie folgt voraus: Inland - EUR 100,- Ausland - EUR 500,-, sofern in unseren Verkaufsunterlagen kein anderweitiger Vermerk gemacht wird. Wir behalten uns vor, Aufträge unter dieser Grenze entweder bis zum Erreichen des Mindestauftragswertes zurückzustellen oder mit einer Bearbeitungsgebühr von EUR 10,- zu belasten.

8. Eigentumsvorbehalt

Die gelieferte Ware bleibt bis zur endgültigen Bezahlung ohne Rücksicht auf den Rechtsgrund unser Eigentum. Für den Fall der Bezahlung auf Scheck-Wechselbasis bleibt der Eigentumsvorbehalt bis zur Einlösung des Wechsels durch den Besteller bestehen.

Der Besteller ist, so lange er sich nicht in Verzug oder in Zahlungsschwierigkeiten befindet, zur Veräußerung der Ware im ordnungsgemäßen Geschäftsverkehr berechtigt. Veräußert der Besteller die in unserem Vorbehaltseigentum stehende Ware, werden die durch die Veräußerung entstehenden Forderungen schon jetzt an uns abgetreten, ohne daß es im Falle der Veräußerung einer ausdrücklichen Bestätigung bedarf. Er ist nicht berechtigt, die Vorbehaltswaren zu verpfänden oder zur Sicherheit an Dritte zu übereignen.

Bis zur endgültigen und vollständigen Bezahlung der Ware steht uns das Recht zu, auch ohne Ausübung des Rücktritts und ohne Nachfristsetzung auf Kosten des Bestellers die einstweilige Herausgabe der Vorbehaltsware zu verlangen, die Räumlichkeiten des Bestellers zu betreten und die Ware nötigenfalls wieder an uns zu nehmen.

Wird eine Be- oder Verarbeitung bzw. untrennbare Vermischung der Vorbehaltsware mit anderen, nicht dem Lieferer gehörenden Gegenständen vorgenommen, so erwerben wir das Miteigentum an der neuen Sache im Verhältnis des Rechnungswertes der Vorbehaltsware zu den anderen verarbeiteten oder vermischten Gegenständen zum Zeitpunkt der Verarbeitung oder Vermischung. Wird die gelieferte Ware vom Besteller oder dessen Beauftragten verändert oder als Teil größerer Einheiten verwendet, so geht unser Eigentum anteilmäßig automatisch auf die veränderte Ware oder die entstanden größeren Einheiten über. Der Besteller verwahrt das Eigentum oder Miteigentum für den Lieferer und ist verpflichtet, diese gegen Feuer, Diebstahl und Wasser zu versichern. Etwaige Entschädigungsansprüche, die aus Schäden vorgenannter Art gegen Versicherungsgesellschaften oder sonstige Ersatzverpflichtete zustehen, werden in Höhe unserer Forderungen an uns abgetreten. Pfändungen oder andere Beeinträchtigungen unseres Eigentums sind uns unverzüglich mitzuteilen.

Ohne die bisher dargelegten Bedingungen einzuschränken, geht das Risiko für die gelieferte Ware vom Tage der Lieferung auf den Besteller über.

9. Lieferzeit, Liefermöglichkeit

Lieferfristenangaben sind annähernd und ohne Verbindlichkeit für uns. Verzugs-spesen und Schadenersatzansprüche bei Lieferverzögerungen können gegen uns in keinem Falle geltend gemacht werden. Die Lieferzeit beginnt nach Klärung sämtlicher kaufmännischer und technischer Einzelheiten. Wir sind berechtigt, Teillieferungen durchzuführen.

10. Höhere Gewalt

Streik und Aussperrung, Katastrophen, Betriebsstörungen, Materialmängel, Verkehrsmängel oder andere Ereignisse höherer Gewalt, ganz gleich ob sie bei uns oder bei unseren Vorlieferanten eintreten, entbinden uns von allen Verpflichtungen.

11. Mängelrügen

Beanstandungen werden nur entgegengenommen, wenn sie schriftlich und umgehend, d. h. sofort nach Erhalt der Sendung, angezeigt werden. Ein Recht auf Wandlung oder Minderung steht dem Besteller nicht zu. Über den Warenwert hinausgehende Ansprüche können nicht gestellt werden. Transportschäden sind stets beim Frachtführer zu reklamieren.

12. Garantie, Gewährleistung

Alle HEYTEC-Werkzeuge werden in unseren Werken sorgfältig überprüft und unterliegen voll der Garantie.

Wir ersetzen jedes Werkzeug kostenlos, das Material- oder Fertigungsfehler aufweist. Eine weitere Haftung ist ausgeschlossen. Kostenloser Ersatz erfolgt nicht, wenn die Untersuchung in unserem Werk ergibt, daß das Werkzeug unsachgemäß behandelt worden ist oder ein natürlicher Verschleiß vorliegt.

13. Haftung

Schadenersatzansprüche aus Fehlen zugesicherter Eigenschaften, Verzug, Unmöglichkeit der Leistung, schuldhafter Verletzung vertraglicher Nebenpflichten, sowie aus Verschulden bei Vertragsabschluß und aus unerlaubter Handlung werden ausgeschlossen, es sei denn, sie beruhen auf Vorsatz oder grober Fahrlässigkeit unserer gesetzlichen oder sonstigen uns zuzurechnenden Vertreter.

14. Erfüllungsort und Gerichtsstand

Erfüllungsort der Lieferung und Zahlung ist Remscheid. Gerichtsstand ist Remscheid. Es gilt das Recht der Bundesrepublik Deutschland.

15. Export und Re-Export

HEYTEC-Ware darf nur mit unserer schriftlichen Genehmigung exportiert oder re-exportiert werden.

Terms of Sale, Delivery and Payment

1. Acceptance of terms of sale, delivery and payment

Our sales are based on the following terms and conditions whereby only the latest issue of our sales literature is valid.

Any variations to these and verbal arrangements require our confirmation in writing. Conditions of the buyer shall not be binding to us, also if not expressly objected by us. The placing of an order contract with us implies acceptance of our conditions. Validity of contract is only reached with our written order confirmation.

2. Quotations

Our offers are without obligation. Catalogue and pricelist form part of our offers. Weights and dimensions, illustrations, performance details, technical drawings and data are subject to change without prior notice, unless contracted and confirmed otherwise.

3. Copyright

All drawings, illustrations, photographs and other documents supplied by us to customers or third parties remain our property and are subject to copyright. They are not to be reproduced or made available to others without our written consent; they are to be stored in a safe place and must be returned to us on demand. Should production of merchandise to drawings, samples or other customer's specification involve an infringement of third party copyrights the customer indemnifies us from and against all claims.

4. Special manufacture

We reserve the right to modify the quantities ordered for special production by plus or minus 10 %, also normal production items, which are marked or finished to buyer's special requirements. Such orders cannot be cancelled once accepted by us. We are unable to accept the return of such items for credit or allowance. If the customer becomes insolvent or bankrupt we reserve the right to sell this merchandise directly. For production to customer's documents the customer shall be solely responsible for the accuracy of drawings, samples, gauges etc. On principle samples are only supplied against invoice.

5. Prices

We reserve the right to adjust prices in case there should be changes in basic production costs, such as raw material, power, wages etc. up to date of delivery. Parts ordered will only be shipped in packing units identified in our sales literature. Smaller quantities or quantities, which are not divisible by packing units will be packed in paper only and levied with an increase of 25 % provided no other information has been given in our sales literature.

6. Terms of payment

Our invoices are payable Home market: 10 days after date of invoice less 2 % cash discount or 30 days after date of invoice net, provided no other arrangements have been agreed. Export markets: According to special arrangements, which are stated on our quotations, proforma invoices, order confirmations and/or invoices. On principle invoice values below EUR 25,- net do not qualify for cash discount. Drafts will only be accepted after prior arrangements and all charges are to buyer's account. In the event of delayed payments or respites we shall charge interests at a rate of 2 % above the bank rate of the Deutsche Bundesbank being in force at the relevant time.

The credit values of cheques and drafts received are entered for that day, when contervalue is at our disposal. In case we should learn about circumstances restricting the creditworthiness of the customer after a contract has been concluded, we are permitted to ask for payment in advance or other satisfactory securities. Retention of payment due to claims of diminution, transformation or other eventual counterclaims as well as settling of accounts incorporating the above is not permissible.

7. Dispatch and delivery

Unless arranged and confirmed to the contrary delivery is effected ex works, packing excluded. Goods are delivered at buyer's risk. Insurance against theft, damages in transit etc. can be arranged on specific request and to customer's account. We reserve the right to choose the most economic method of transport unless particular instructions are given.

Goods, which have been packed to be ready for dispatch for an agreed date must be called off immediately, as otherwise we are entitled to store same at buyer's risk and cost and to invoice shipment as delivered.

For shipments our minimum net order values are - Home market EUR 100,- Export markets EUR 500,-, unless no other terms are quoted in our sales literature. Terms of Sale, Delivery and Payment. For orders with smaller values we reserve the right to postpone shipment until minimum order value is reached or to charge a handling fee amounting to EUR 10,00.

8. Title to the goods

Goods delivered remain our property until payment is received in full. It is expressly reserved that any law contradicting this clause shall not impair our rights concerning our goods. The buyer may dispose of the goods in the usual businesslike manner provided he is not insolvent or in default. Should the customer sell goods, which are still our property respective credit is due to our account automatically without express confirmation. The buyer is not entitled to distrain or, as security to third parties, assign goods which are still our property.

Until paid for in full we are entitled to demand the release of goods and to enter buyer's premises with the object of re-taking possession of the goods. We are not obliged to execute withdrawal and to award postponement at customer's costs.

In case processing, further treatment or inseparable blending of provisosgoods is effected with other merchandise or parts not belonging to us, we automatically gain partial ownership on the processed goods to such value as it is in relation to the processed or blended merchandise at the moment of processing or blending. Should supplied goods through buyer or on behalf of buyer be subjected to alterations or be used as part of larger units, then automatically partial ownership is transferred to the changed merchandise or the produced larger units. The buyer storing seller's property or partial property is obliged to secure same against fire, theft and water. Eventual claims for damages against insurance companies resulting from damages mentioned before are to be assigned to us representing the amount of our claim. Distraints and/or any other limitation, which might be imposed on our property despite the reservations outlined in the preceding sentences must be reported immediately.

Notwithstanding the conditions outlined above, goods are at the entire risk of the buyer from the date of delivery.

9. Time of delivery and delays

All information given in respect of delivery period is approximate and without obligation. Liability in case of delay in delivery, interest for delay and/or damages cannot be accepted. The time of delivery begins only after clarification of all clerical and technical details. We are permitted to effect part shipments.

10. Force majeure

Force majeure, such as strike and lock-out, catastrophes of any kind, breakdown in supply of any kind, delivery of faulty material or other restrictions through force majeure shall release us from our liabilities, no matter if occurred with us or our sub-suppliers.

11. Claims

Claims must be made immediately on receipt of the goods and in writing, as otherwise such claims will not be accepted by us. Amendments to or deductions from invoices will not be accepted. The customer is not entitled to make claims above the nominal value of the goods involved. Damages in transit are to be claimed with the carrier.

12. Guarantee, warranty

All HEYTEC tools are carefully tested before leaving our works and are fully guaranteed. We shall replace free of charge any tool indicating faults of material and workmanship. Any further liability is excluded. Tools returned as faulty, which on inspection/test prove to have failed due to abuse, incorrect use or fair wear and tear are excluded from this guarantee and replacement will be charged.

13. Liability

Claims for compensation due to missing of promised features, delays, impossibility of performance, guilty violation of contractual secondary obligations, faults with conclusion of contract as well as unauthorized action are excluded save where our legal representatives are shown to have acted on purpose or negligently. Liability even for careless violation is limited to compensation, which is foreseeable at the moment of conclusion of contract.

14. Settling place and place of competency

Remscheid is the settling place for delivery, payment and competency of justice in case of dispute. Only the law of the Federal Republic of Germany shall govern.

15. Export and re-export

Only with our written approval HEYTEC goods may be exported or re-exported.

Abkürzungen, Symbole
und Hinweise

Packeinheit



Länge



Durchmesser

metrische Schlüsselweiten
für Schrauben und Muttern
mit Außensechskantmetrische Schlüsselweiten
für Innensechskantschrauben

Schlüsselweite bei TORX®-Schrauben



Innensechskant Schon-Profil



Innen-Doppelsechskant Schon-Profil



für Außen-TORX®-Schrauben



Innenvierkant



Außenvierkant

Außensechskant u. für
Innensechskantschrauben

für Schlitzschrauben

für Kreuzschlitzschrauben
PHILLIPS-RECESS

für Kreuzschlitzschrauben POZIDRIV®



für Innen-Keilprofil-Schrauben RIBE CV



für Innenvielzahn-Schrauben XZN



für Innen-TAMPER-TORX®-Schrauben



für Innen-TORX®-Schrauben

POZIDRIV®

eingetragenes Warenzeichen der
Firma European Industrial Services Ltd.

TORX®

eingetragenes Warenzeichen der
Firma CAMCAR/TEXTRON INC.

D

Alle Katalogartikel werden technisch ständig optimiert; daher sind Änderungen jederzeit und ohne Ankündigung möglich. Unsere Katalogpreise sind Grundpreise ohne Mehrwertsteuer. Sie sind bei Weiterverkauf durch den Handel als unverbindliche Preisempfehlung anzusehen und nicht zur Weitergabe bestimmt. Der Nachdruck dieses Kataloges oder Teilen daraus, die Vervielfältigung, Speicherung und Übermittlung jedweder Art, auch durch Datenverarbeitungsanlagen, sind nur mit unserer schriftlichen Genehmigung gestattet.

Abbreviations, symbols
and notes

packing unit



length



diameter

spanner openings in metric
for hexagon head screws,
bolts and nutssizes in metric for hexagon
socket screws and bolts

size in millimetres for TORX®-screws



inside hexagon (profile saver)



inside bihexagon (profile saver)



for TORX®-head screws



inside square



outside square

outside hexagon –
for hexagon socket screws

for plain slot screws

for cross slot screws
PHILLIPS-RECESS

for cross slot screws POZIDRIV®



for multi-spline socket screws XZN



for fluted socket screws RIBE CV



for TAMPER-TORX®-socket screws



for TORX®-socket screws

POZIDRIV®

Registered trade mark
of European Industrial Services Ltd.

TORX®

Registered trade mark
of CAMCAR/TEXTRON INC.

GB

All catalogue articles are continuously updated to the latest technical standards. As a result, specifications are subject to change without prior notice. Our catalogue prices are gross-prices, excluding value added tax. They are to be considered as recommended retail prices. Reprint of this catalogue or parts thereof, reproduction, storage in retrieval systems, unauthorized utilization and transmission in any form or by any means including computer systems is only permitted with our prior consent in writing.

Abréviations, symboles
et indications

unité d'emballage



longueur



diamètre

ouvertures métriques pour vis
et écrous hexagonauxouvertures métriques
pour vis 6 pans creux

ouvertures métriques pour vis TORX®



6 pans intérieur – profil d'usure



12 pans intérieur – profil d'usure



pour vis TORX® extérieures



carré femelle



carré mâle



6 pans mâle



pour vis à fente

pour vis cruciformes
PHILLIPS-RECESS

pour vis cruciformes POZIDRIV®



pour vis denture multiple XZN



pour vis à empreinte à arêteaux RIBE CV



pour vis TORX® intérieures



pour vis TEMPER-TORX® intérieures

POZIDRIV®

marque déposée par la société
European Industrial Services Ltd.

TORX®

marque déposée par la société
CAMCAR/TEXTRON INC.

F

Les produits du catalogue étant soumis à des améliorations techniques permanentes, le fabricant se réserve le droit de modifier leurs caractéristiques à tout moment et sans préavis. Les prix indiqués dans ce catalogue sont des prix de base hors T.V.A. Ils sont donnés à titre indicatif aux revendeurs et ne sont pas destinés à être divulgués. Toute reproduction, copie ou diffusion totale ou partielle que ce soit, notamment par photocopie ou par équipement informatique, est interdite sans notre autorisation écrite.

Abreviaturas, símbolos
e información

unidad de envase



longitud



diámetro

medidas métricas para tornillos y
tuercas con hexágono exteriormedidas métricas para tornillos
con hexágono interior

medidas para tornillos TORX®



hexágono interior, perfil protector



estrella interior, perfil protector



para tornillos TORX® exteriores



cuadradillo interior



cuadradillo exterior



hexágono exterior



para tornillos ranurados

para tornillos
PHILLIPS-RECESS

para tornillos POZIDRIV®



para tornillos XZN



para tornillos RIBE CV



para tornillos TAMPER TORX® interiores



para tornillos TORX® interiores

POZIDRIV®

marca registrada de
European Industrial Services Ltd.

TORX®

marca registrada de
CAMCAR/TEXTRON INC.

E

Todos los artículos del catálogo están sometidos a perfeccionamiento continuo. Por eso, están sujetos a posibles modificaciones sin previo aviso. Observen que los datos contenidos en las tablas están solamente en alemán e inglés. Para condiciones de venta, envío y pago, índice alfabético véanse catálogos en vigor. El presente catálogo – tarifa refleja precios de venta al público recomendados, por pieza/juego, I.V.A. no incluido. La reproducción íntegra o parcial de este catálogo, su copia, registro o retransmisión de cualquier tipo, incluso por medios informáticos, requieren obligatoriamente nuestra autorización escrita.

HEYTEC

TOOLS

**Das Werkzeug
für Clevere!**



HEYTEC

TOOLS



